

FEATURES

- Includes 5 watt solar panel, mounting hardware, and 12V solar charge controller
- Reliable, maintenance-free operation
- Powers most Seametrics products with the addition of a low cost 22-33 Amp-hour Sealed Lead Acid battery (battery not included)

APPLICATIONS

- Remote metering applications where electricity is unavailable
- Back-up power supply for uninterrupted operation



GENERAL INFORMATION

The RSP5 solar panel makes it possible to use Seametrics flowmeters in remote applications where a reliable source of electricity is not available or practical. The RSP5 is intended for use with a standard 12V, 22-33 Amp-hour Sealed Lead Acid battery (not included). It comes standard with a charge

controller and corrosion-resistant mounting hardware. The RSP5 can also be used to provide up to a 40-day back-up power supply for periods of darkness.

SPECIFICATIONS*

Electrical	Current	290 mA (typical at design operating point)
	Voltage	17 V (typical at design operating point)
Dimensions	Height	14.2" (36.068 cm)
	Width	8.5" (21.59 cm)
	Weight	4 lbs. (1.8144 kg) (solar panel and mounting bracket)
Mounting	Bracket, band clamps and mounting hardware for 1-1/2 or 2 inch vertical pipe	
Operating Temperature Range	-40° F to +158° F (-40° C to +70° C)	
Charge Controller	High efficiency series PWM regulator with temperature compensation and built-in lightning protection	

*Specifications subject to change • Please consult our website for current data (www.seametrics.com).

BATTERY SELECTION

For powering Seametrics mechanical meters along with display electronics, use a 12V Sealed Lead Acid (SLA) deep-cycle battery with a minimum capacity of 22 Amp-hours. This should provide a conservative 40 day backup with maximum battery service life. Marine/RV grade deep-cycle batteries or automotive batteries may be used but must be upsized in Amp-hour capacity by two times and four times respectively to achieve the same battery service life in most applications.

For powering Seametrics low power (<50mA) magnetic flow meters (AG2000, WMP, WMX and low power EX-Series, etc.) use only deep-cycle SLA batteries (not marine/RV or automotive grade batteries) with a minimum capacity of 33 Amp-hours. In climates where meters are operating in full pipe

mode much of the time with extended periods of cloudy days, operating continuously through the year, or in latitudes above 50 degrees, the required battery Amp-hour capacity should be reviewed before selection. To learn more, consult the Appendix in our solar power application note found at www.seametrics.com.

In summary, the minimum recommended battery capacity, as described above, will be adequate in most climates and applications. However, under marginal conditions, a larger capacity battery may provide superior reliability, better battery service life and lower life-cycle costs.

LOCATION

The solar panel should be oriented as much as possible toward the midday sun. Locate where there is no significant shading of the solar panel. The Solar Charge Controller and Sealed Lead Acid (SLA) battery should be located in close physical and thermal proximity. Both must be shaded from direct sunlight to minimize temperature differences between them which will greatly diminish the battery service life. Also insulate the bottom of the battery if heat could be absorbed from the surface (concrete, metal etc.) on which the battery is resting. Also take measures to prevent accumulation of moisture (rain, snow, ice, flooding) between the battery terminals which could discharge the battery.

If the battery and Solar Charge Controller are housed in an enclosure, the outside must be white or shiny metallic to minimize solar heat build up inside that is seriously detrimental to the service life of the battery. Even light colors (such as the standard ANSI 61 Gray) can elevate the interior of the enclosure by 40F (22C.) If other colors are used, the enclosure must be shaded from direct sunlight or painted glossy white. In addition, because even sealed batteries could vent if the Solar Charge Controller fails, for safety reasons the enclosure should be vented, particularly if it contains other electrical equipment.

INSTALLATION

The solar panel is designed to mount to either a 1-1/2 to 2 inch diameter vertical pipe. First, locate and record the product code (either 'D' or 'R') on the box label.

To install product code 'D' panels, attach the 45 degree angle bracket to the panel with the two M6 bolts, flat washers and nuts provided as shown. **Before tightening the bolts. Be sure to position the bracket to the side of the black cable cover rather than over it to avoid stressing the panel.**

To install product code 'R' panels, the 45 degree angle bracket is mounted to the two center holes on the rear of the panel with the two M6 bolts, flat washers and nuts provided as shown. Cut off and discard the ring lugs on the panel wires.

At latitudes above 50 degrees performance may be improved by bending the angle bracket so that the angle of the panel to the horizontal is increased to approximately the local latitude plus 15 degrees. **To avoid damage to the panel, do this before bolting the bracket to the panel.** Next use the two sets of 1/4-20 bolts, nuts, flat and lock washers to attach the angle

bracket to the pipe mount C-channel. Then attach the entire assembly to the pipe using the two band clamps as shown. Turn the panel to face true (not magnetic) south in the northern hemisphere or north in the southern hemisphere before tightening the clamps securely.

Connect the solar charge controller, flow meter and battery as shown in the wiring diagram. Clean battery terminals and secure connections to the battery using grease or other means of preventing corrosion. For safety, the in-line fuse holder should be installed at the positive battery connection with a 1 Amp time lag (slow-blow) fuse. In unprotected locations the included weatherproof fuse holder and outdoor-rated wirenuts should be used. The sealed lead-acid battery should have an ampere-hour (Ah) rating sufficient to maintain the battery charge level above 50% at all times. Automotive or marine deep-cycle batteries are not recommended due to short life times in most climates.

Download the Technical Bulletin "Solar Power Installations" on the Seametrics website (www.seametrics.com) for more information.

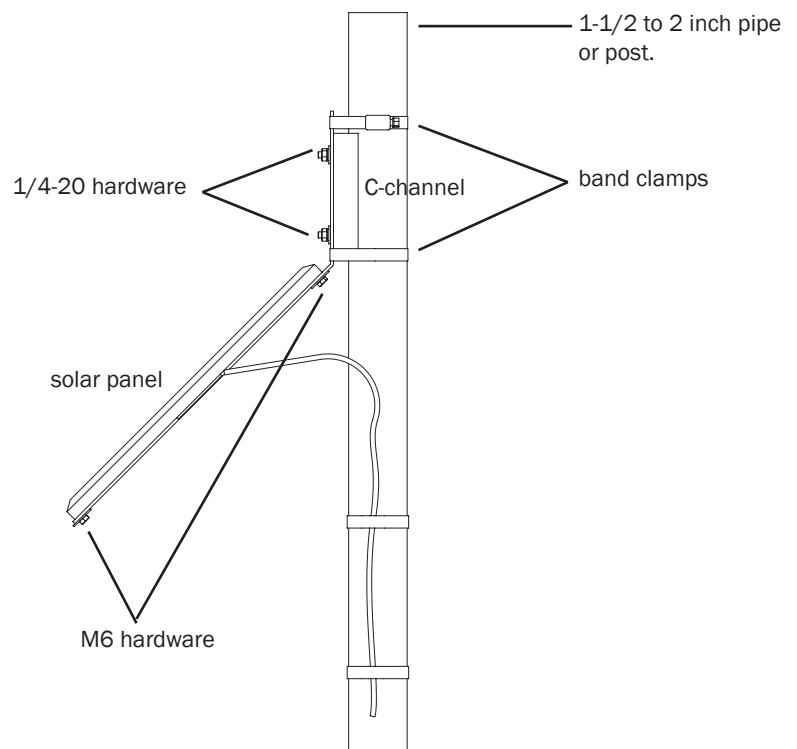
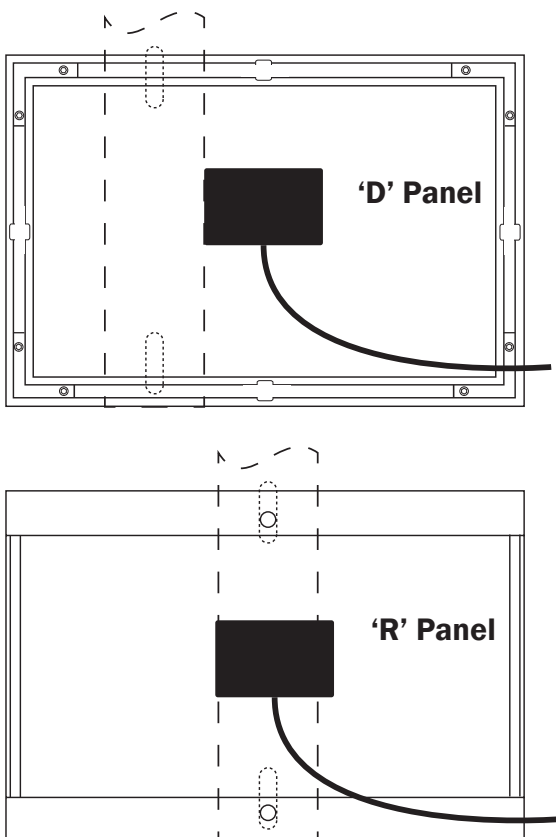

WIRING DIAGRAM

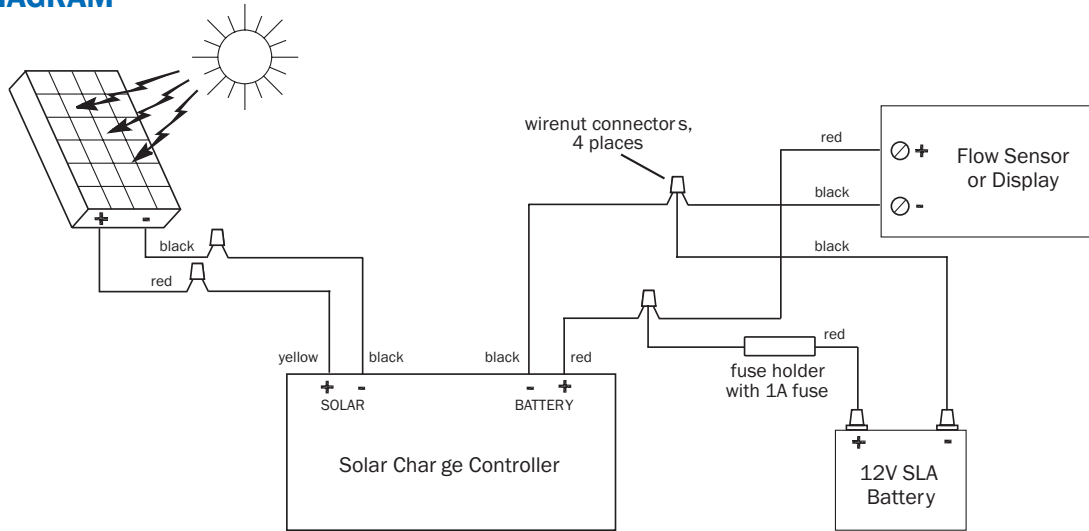

MAINTENANCE

Periodic cleaning of the solar panel glass is recommended to remove dust accumulation. Snow and ice may need removal if it remains more than 2 weeks. Installing the panel at a steeper than 45 degree angle may make this unnecessary in

most areas. Battery service life for good quality SLA batteries should be 4-6 years. Actual maintenance replacement interval will depend on local conditions and criticality of data.

User is responsible for reviewing end use application with their supplier for product suitability.

CONTACT YOUR SUPPLIER