

# IP80-Series

*Seametrics*

## FLOW SENSOR INSTRUCTIONS

- IP81
- IP82

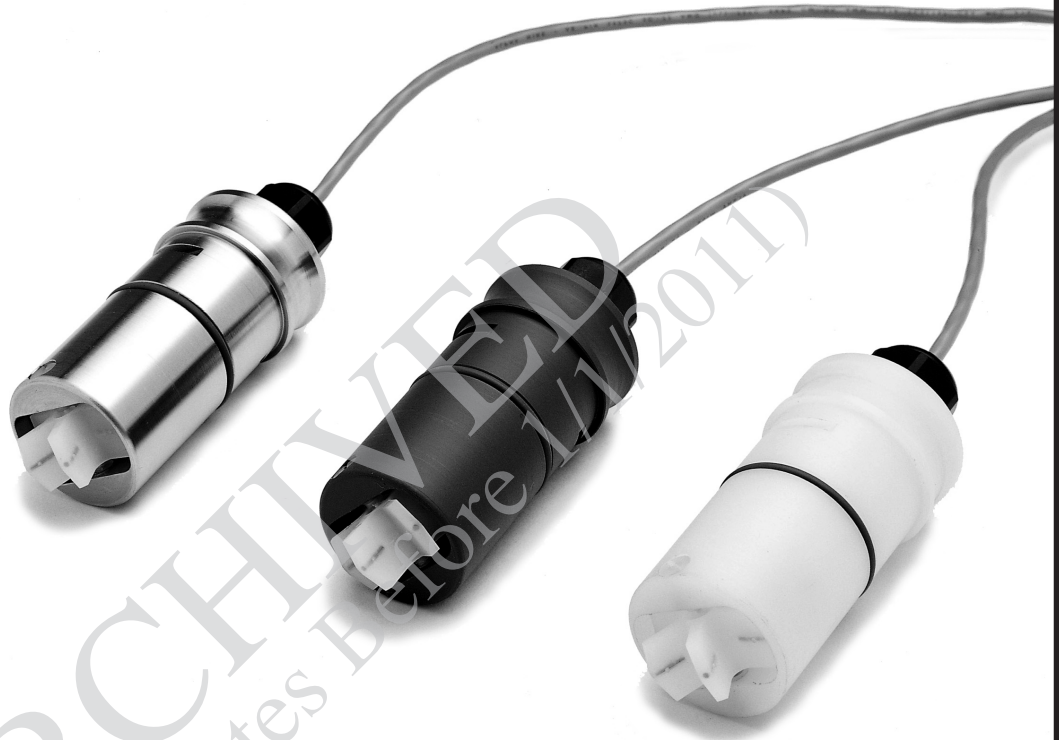

ARCHIVED  
(Includes Dates Before 1/1/2011)

IP80-SERIES FLOW SENSOR INSTRUCTIONS

**ISO** 9001:2008  
CERTIFIED

## TABLE OF CONTENTS

---

### General Information

Features, Specifications ..... Page 3

### Installation

Insertion Depth, K-Factor, Distorted Flows, Fitting Installation, Meter Installation, Positioning the Meter ..... Page 4

Straight Pipe Recommendations ..... Page 5

Full Pipe Recommendations ..... Page 6

### Connection Diagrams

FT415/FT420/A055, Connecting to PLC's..... Page 7

### Operation

Minimum Flow, Flow Range Table, Calibration ("K-Factor"), K-Factor Chart, Field Calibration..... Page 8

### Maintenance

Rotor Replacement, Signal Troubleshooting, Sensor Replacement ..... Page 9

### Parts Explosion

Parts List ..... Page 10

### Troubleshooting

Problems, Probable Causes, To Check, To Repair ..... Page 11

## TABLES AND DIAGRAMS

---

Specifications, Features ..... Page 3

Distorted Flows, Positioning the Meter ..... Page 4

Straight Pipe Recommendations ..... Page 5

Full Pipe Recommendations ..... Page 6

Connections Diagrams ..... Page 7

Flow Range Table, K-Factor Number on Tee Fitting, K-Factor Chart, Pressure vs. Temp Chart .....Page 8

Rotor and Sensor Replacement ..... Page 9

Parts Explosion, Parts List ..... Page 10

Troubleshooting..... Page 11

## GENERAL INFORMATION

The **IP80-Series** are impeller (or “paddlewheel”) insertion meters designed for use with a wide variety of liquids in pipe sizes 1/2" to 8". Sensors are available in brass, 316 stainless steel, PVC, and polypropylene. Bodies are machined from a solid rod for maximum precision. High-quality jewel bearings and nickel-bound tungsten carbide shafts are used for extreme low friction and long life. Low-flow performance is good, although other Seametrics flow meters are recommended where extremely low flows are being measured.

The rotation of the rotor is detected by a non-drag Hall-effect sensor. Output is a current-sinking pulse (square wave), which can be sent long distances (up to 2,000 feet) without a transmitter. This signal can be connected directly to PLC's, counters, and computer cards, as well as a variety of Seametrics controls and displays.

Seametrics IP meters are ideal for chemical proportioning applications. If no display is required, a simple divider such as the PD10 provides adjustable pump pacing. For rate and total display, the FT415 (battery powered) or FT420 (loop powered) flow indicator can be mounted directly on the IP80-Series meter, or remotely on a wall or panel. The AO55 blind analog transmitter can be used to convert to a 4-20 mA output. IP meters are also compatible with the DL76 data logger and FT520 batch processor.

The IP80-Series require special fittings that ensure correct depth placement in the pipe. Fittings come in a variety of materials for compatibility with specific applications. Tee fittings are individually wet-calibrated at the factory and marked with the K-factor (pulses per gallon). Saddle fittings must be field-installed on the pipe and do not come wet-calibrated. K-factors for saddles are based on factory-testing.

## FEATURES

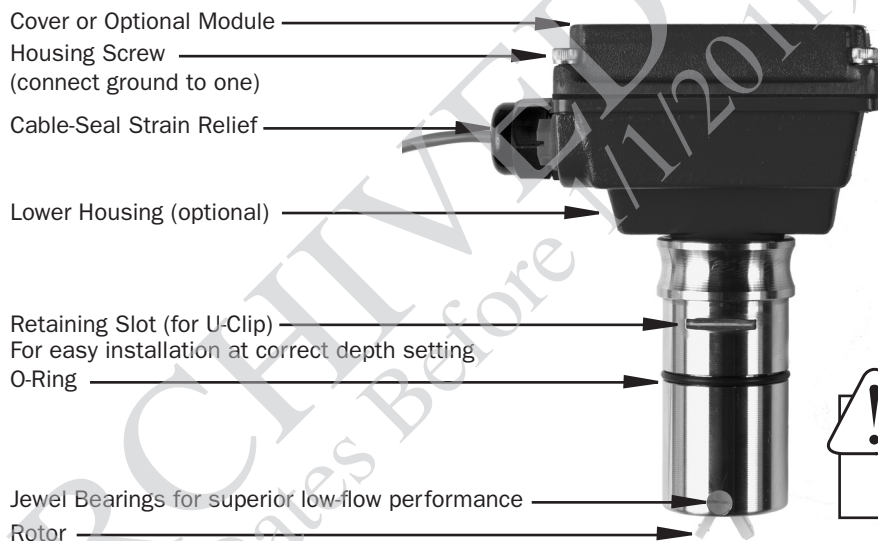

## SPECIFICATIONS\*

<b>Materials</b>	<b>Sensor Body</b>	Brass, 316 Stainless Steel, PVC, or Polypro		
	<b>Rotor</b>	PVDF		
	<b>Shaft</b>	Nickel-bonded tungsten carbide (Ceramic optional)		
	<b>Bearings</b>	Ruby jewel		
	<b>O-Ring</b>	EPDM (Viton optional)		
<b>Rotor Pickup</b>	GMR (Giant Magnetoresistive) Sensor			
<b>Maximum Pressure</b>	<b>Brass</b>	<b>316 SS</b>	<b>PVC or Polypro</b> (See Pressure vs. Temp. Chart)	
	200 PSI (14 bar)	250 PSI (17 bar)	175 PSI (12 bar) @ 75° F	
	<b>Maximum Temperature</b>	200° F (93° C)	200° F (93° C)	130° F (55° C)
<b>Flow Range</b>	0.3 - 30 ft./sec.			
<b>Accuracy</b>	+/- 1.5% of full scale			
<b>Signal</b>	Hall effect current sinking pulse			
<b>Power</b>	6-24 Vdc, 2 mA			
<b>Maximum Current</b>	20 mA			
<b>Cable</b>	#22 AWG, 3 Cond, 18 foot (maximum 2000' run)			
<b>Regulatory</b>	CE Mark (Stainless Steel, Brass and Standard Power Only)			

\*Specifications subject to change • Please consult our website for current data ([www.seametrics.com](http://www.seametrics.com)).

## INSTALLATION

**Insertion Depth.** The IP80-Series are fixed-depth meters that must be used with matched fittings appropriate to the application and pipe size. This ensures that the flow sensor is installed at the correct insertion depth to measure the average flow velocity of the stream.

**K-Factor.** Each flow sensor/tee fitting pair is wet calibrated at the factory and marked with the correct K-factor. Saddle fittings cannot be factory-calibrated at the proper insertion depth because the fitting must first be installed on the pipe in the field; therefore, K-factors for saddle fittings are derived through testing with standard pipe schedules and included with the meter. In PVC, however, it is possible to order a saddle pre-installed on a standard length of pipe, and the fitting can be wet-calibrated in this case.

**Straight Pipe.** Straight pipe of at least 10 diameters upstream and five diameters downstream of the meter is strongly recommended for proper accuracy. This is necessary because the shape of the velocity profile changes as the rate increases around an elbow; placing the meter too near the elbow causes a distorted reading. Additional straight run may be needed under specific adverse circumstances (see next page).

### DISTORTED FLOWS

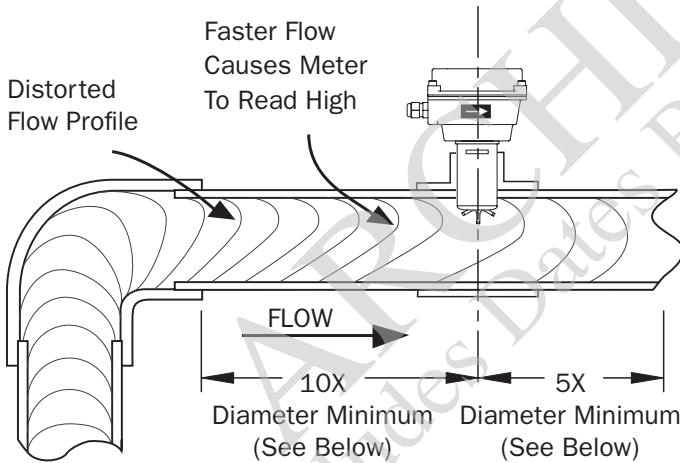

If you can't provide enough straight run to smooth out the velocity profile, some decrease in accuracy may result. This does not mean the meter's reading is meaningless, however. In some applications (e.g., control system, valve operation) a repeatable reading may be more important than a highly accurate one.

**Fitting Installation.** Stainless steel and brass fittings have female pipe threads, requiring the appropriate male threaded fittings. Saddle fittings require a hole to be cut in the pipe (recommended hole size is 1-3/4"). Before cutting into the pipe, observe the drawing below to choose your meter orientation.

### POSITIONING THE METER

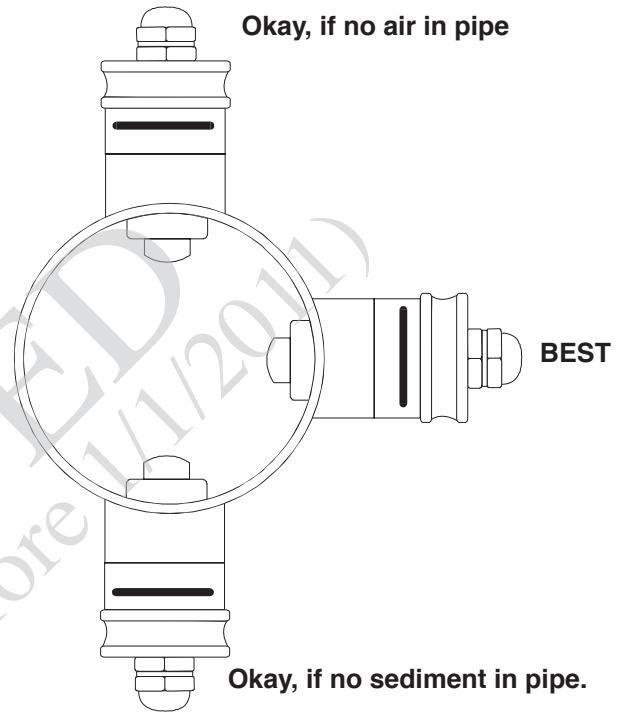

**PVC Fittings.** A PVC fitting is usually installed by solvent welding. PVC tees are supplied with some upstream straight pipe, less than the recommended straight pipe requirements. It is not advisable to connect directly to the end of these fittings with a flow disturbing device (valve, elbow), but rather add straight pipe to the end of these fittings to meet the straight pipe requirements for your application.

**Meter Installation.** After the meter fitting is installed in the pipeline, the meter can be installed in the fitting. Press the meter into the fitting as far as it will go. Retain the meter in place by inserting the u-pin. The pin can be installed from either side. It may be necessary to rotate the probe back and forth slightly to start the pin into the slots on the probe. Slide the pin in as far as it will go.



**Caution:** Never remove the u-clip retainer when the pipe is under pressure. Always remove pressure from the pipe before you attempt to remove the meter. Removal under pressure may result in damage or serious injury.

# INSTALLATION

## STRAIGHT PIPE RECOMMENDATIONS

(X = diameter)

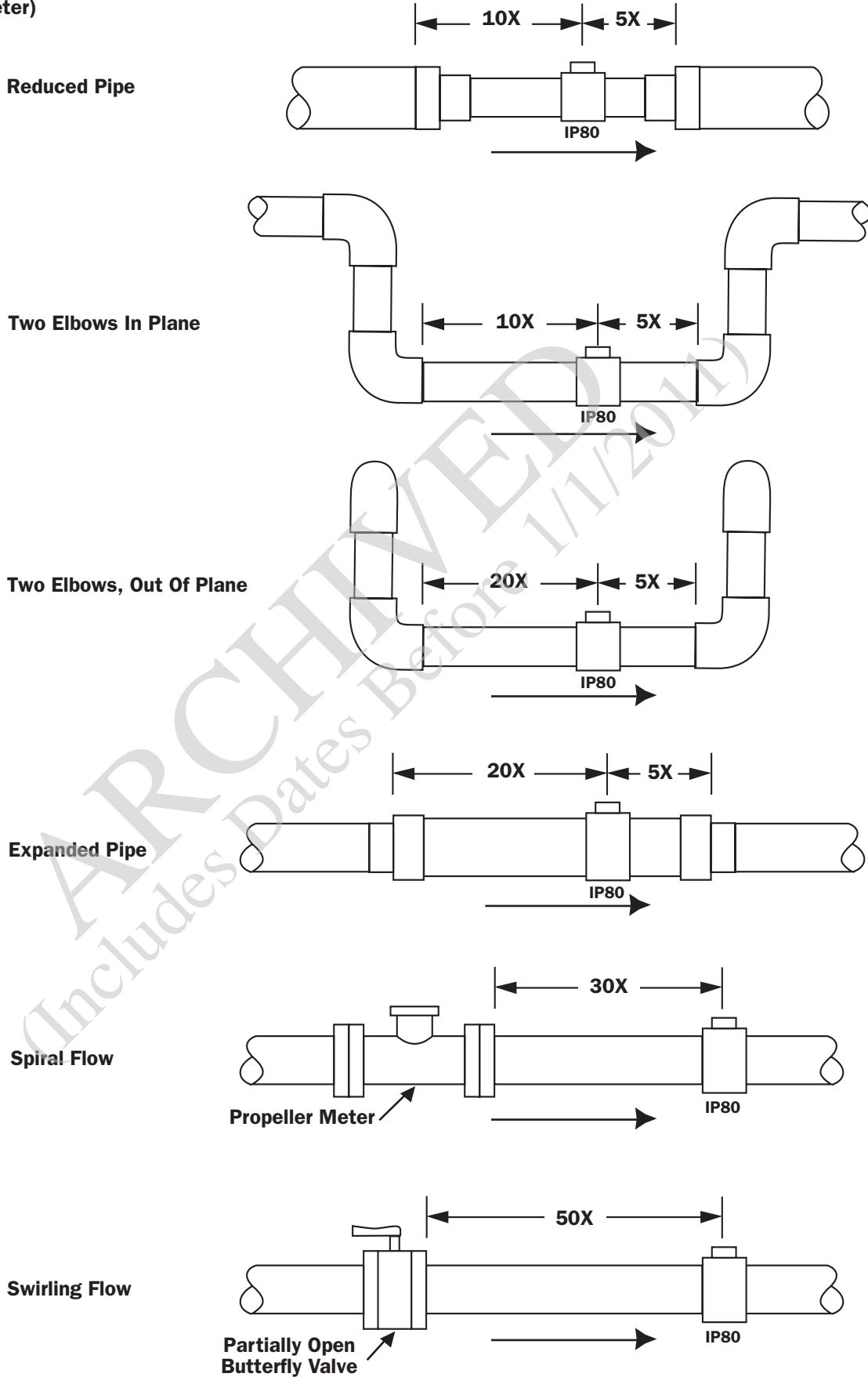

# INSTALLATION

## FULL PIPE RECOMMENDATIONS

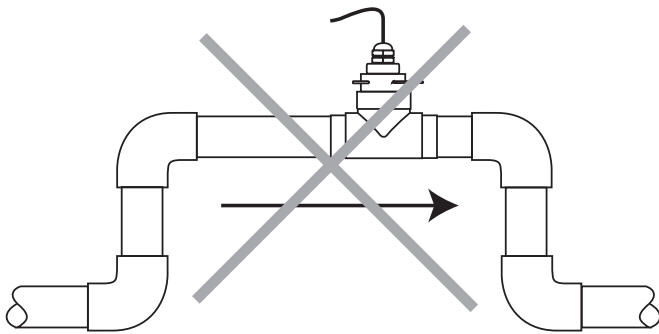

**Possible Problem:**  
Allows air pockets to form at sensor

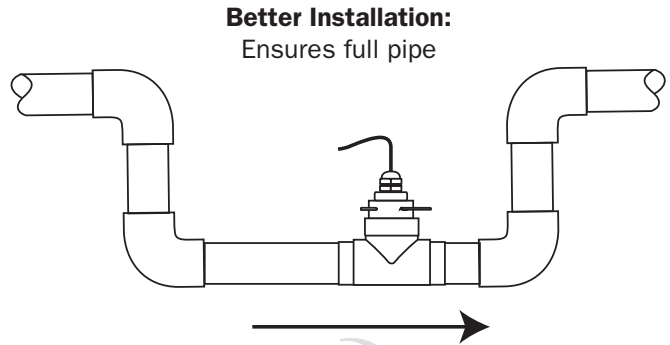

**Better Installation:**  
Ensures full pipe

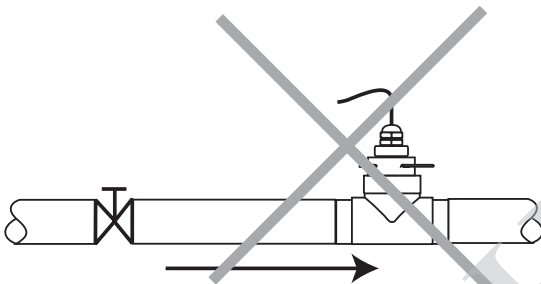

**Possible Problem:**  
Post-valve cavitation can create air pocket

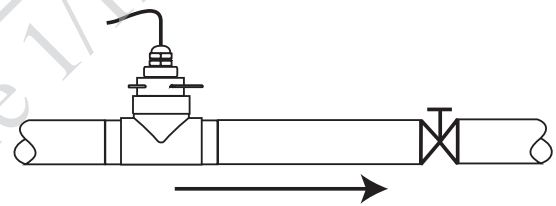

**Better Installation:**  
Keeps pipe full at sensor

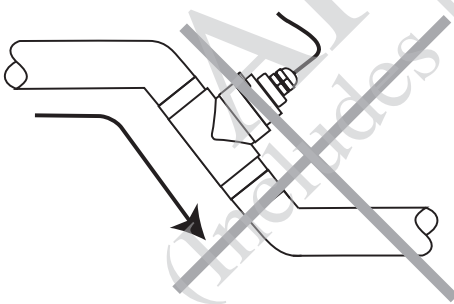

**Possible Problem:**  
Air can be trapped

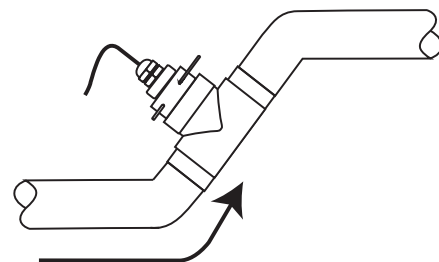

**Better Installation:**  
Allows air to bleed off



**Caution:** These flow sensors are not recommended for installation downstream of the boiler feedwater pump where installation fault may expose the flow sensor to boiler pressure and temperature. Maximum recommended temperature is 130°F (Plastic), 200°F (Metal).













