

EcoPRO-Series



4-20mA SUBMERSIBLE PRESSURE TRANSMITTER INSTRUCTIONS



EcoPRO-Series 4-20mA SUBMERSIBLE PRESSURE TRANSMITTER INSTRUCTIONS



Table of Contents

Introduction - EcoPRO-Series 4-20 mA Transmitters	2
Initial Inspection and Handling.....	2
Do's and Don'ts	2
General Information.....	3
Installation.....	5
Monitoring Wells	5
Other Installations.....	6
Maintenance.....	6
Desiccant Tubes	6
Miscellaneous	7
Troubleshooting	7
Erratic Readings.....	7
Oscillating Readings Over Time.....	7
Zero Readings When Pressurized.....	8
Technical Specifications.....	8
Component and Wiring Information.....	9
Mechanical Specifications	10
Electrical Specifications	10
Adaptors.....	11
Reordering Information	11
Accessories	11

Introduction - EcoPRO-Series 4-20 mA Transmitters

These pressure transmitters represent the latest state-of-the-art technology and have been designed to provide trouble-free submersible operation in liquid environments, when properly installed and operated. Please take the time to read through this manual if you are not familiar with this product.

Initial Inspection and Handling

Upon receipt of your transmitter, inspect the shipping package for damage. If any damage is apparent, note the signs of damage on the appropriate shipping form. After opening the carton, look for concealed damage such as a cut cable. If concealed damage is found, immediately file a claim with the carrier.

Check the etched label on the transmitter to be sure that it is the proper range and type. Also, check the label attached to the cable at the connector end for the proper cable length.

Do's and Don'ts

Do handle the device with care.

Do store the device in a dry, thermally-stable environment when not in use.

Do install a desiccant tube if you are doing long-term outdoor monitoring.

Don't install the device so that the connector end is submerged.

Don't support the device with the connector or with the connectors of an extension cable. Use a strain relief device to take the tension off the connectors.

Don't allow the device to free-fall down a well at high velocities as impact damage can occur.

Don't bang or drop the device on hard objects.

Don't disassemble the device. (The warranty is void if transmitter is disassembled.)

General Information

The following paragraphs outline the basics of how pressure is measured using submersible pressure transmitters:

Liquids and gasses do not retain a fixed shape. Both have the ability to flow and are often referred to as fluids. One fundamental law for a fluid is that the fluid exerts an equal pressure in all directions at a given level. Further, this pressure increases with an increasing depth of “submergence”. If the density of a fluid remains constant (noncompressible...a generally good assumption for water at “normal” pressures and temperatures), this pressure increases linearly with the depth of “submergence”.

We are all “submerged” in the atmosphere. As we increase our elevation, the pressure exerted on our bodies decreases as there is less of this fluid above us. It should be noted that atmospheric pressure at a given level does vary with changes in the weather. One standard atmosphere (pressure at sea level on a “normal” day) is defined to be 14.7 PSI (pounds per square inch).

There are several methods to reference a pressure measurement. Absolute pressure is measured with respect to an ideal vacuum (no pressure). Gauge pressure is the most common way we express pressure in every day life and is the pressure exerted over and above atmospheric pressure. With this in mind, gauge pressure (P_g) can be expressed as the difference between the absolute pressure (P_a) and atmospheric pressure (P_{atm}):

$$P_g = P_a - P_{atm}$$

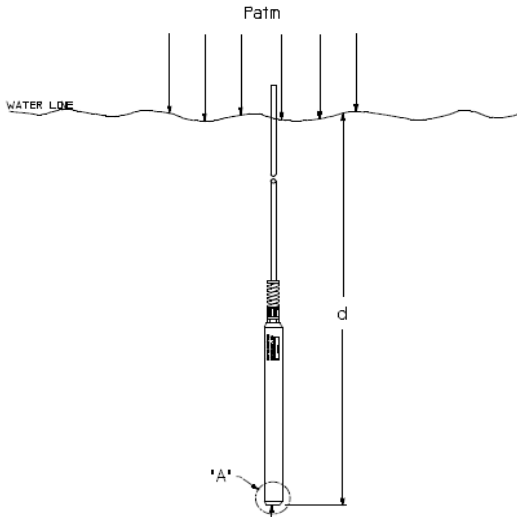

Pressure Diagram

To measure gauge pressure, atmospheric pressure is subjected to one side of the system and the pressure to be measured is subjected to the other. The result is that the differential (gauge pressure) is measured. A tire pressure gauge is a common example of this type of device.

Recall that as the level of submergence increases (in an incompressible fluid), the pressure increases linearly. Also, recall that changes in weather cause the absolute atmospheric pressure to change. In water, the absolute pressure P_a at some level of depth (d) is given as follows:

$$P_a = P_{atm} + kd$$

where k is simply a constant (i.e.: 2.307 ft of water = 1 PSI)

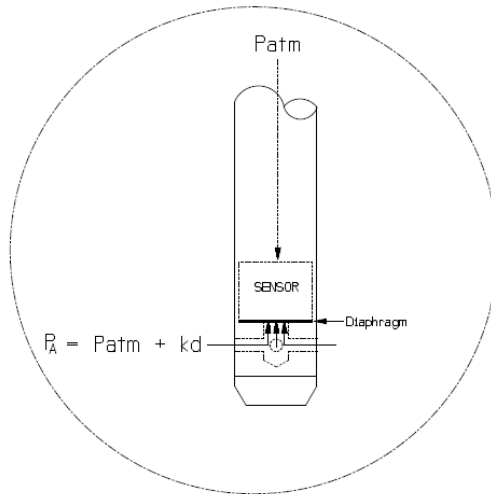

DETAIL "A"

Pressure Diagram, Detail "A"

Seametrics' standard gauge submersible pressure device utilizes a vent tube in the cable to allow the device to reference atmospheric pressure. The resulting gauge pressure measurement reflects only the depth of submergence. That is, the net pressure on the diaphragm is due entirely to the depth of submergence.

Installation

The EcoPRO measures pressure and optionally temperature (EcoPRO+ only) . The most common application is measuring liquid levels in wells and tanks. In order to do this, the transmitter must be installed below the water level at a fixed depth. The installation depth depends on the range of the transmitter. One (1) PSI is equal to approximately 2.31 feet of water. If you have a 5 PSI transmitter, the range is 11.55 feet of water and the transmitter should not be installed at a depth below 11.55 feet. If the transmitter is installed below its maximum range, damage may result to the transmitter and the output reading will not be correct.

Monitoring Wells

Lower the transmitter to the desired depth. Fasten the cable to the well head using tie wraps or a weather proof strain-relief system. When securing the cable, make sure not to pinch the cable too tightly or the vent tube inside the cable jacket may be sealed off. Take a measurement to insure the transmitter is not installed below its maximum range. It is recommended that several readings be taken to insure proper operation after installation.

Important Note: If the transmitter is to be left in the well for a long-term monitoring application and the connector end is not in a dry, thermally-stable environment, a desiccant tube must be installed in line with the cable to prevent condensation in the cable vent tube. Water in the vent tube will cause inaccurate readings and, in time, will work its way into the transmitter and damage it.

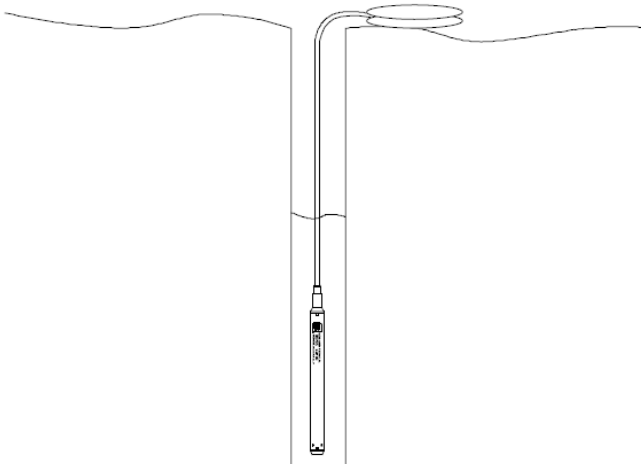

Installation

Other Installations

The transmitter can be installed in any position; however, when it leaves the factory it is tested in the vertical position. Strapping the transmitter body with tie wraps or tape will not hurt it. If the transmitter is being installed in a fluid environment other than water, be sure to check the compatibility of the fluid with the wetted parts of the transmitter. Seametrics can provide a variety of seal materials if you are planning to install the transmitter in an environment other than water.

Maintenance

Desiccant Tubes

On vented sensors, inspect the desiccant tube at least once every two months. The desiccant tube prevents moisture in the air from being sucked into the vent tube, which can cause erratic readings and sensor damage.

The desiccant tube is filled with blue silica gel beads. A locking barb and a hydrophobic water filter are attached to the end of the desiccant tube. This filter prolongs the life of the desiccant as much as three times over a desiccant tube without the filter.

Install the sensor so that the desiccant tube will not flood or lie in water.

The desiccant is a bright blue color when active and dry. As moisture is absorbed the color will begin to fade, becoming a light pink, which indicates full saturation and time to replace. Replacement desiccant and hydrophobic filters can be purchased from Seametrics.

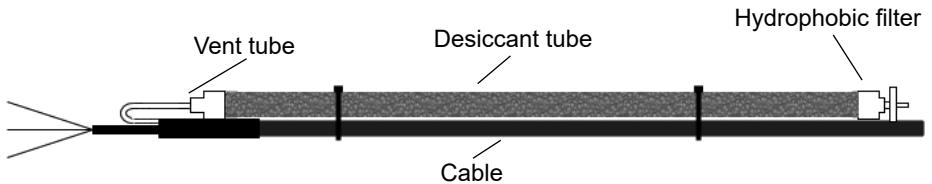

The desiccant tube prevents water intrusion through the vent tube. Be sure to replace the desiccant when it turns pink, as that indicates it is saturated.

Miscellaneous

Sensor: There are no user-serviceable parts, other than the batteries. If problems develop with sensor stability or accuracy, contact Seametrics. If the transducers have been exposed to hazardous materials, do not return them without notification and authorization.

Cable: Cable can be damaged by abrasion, sharp objects, twisting, crimping, crushing, or pulling. Take care during installation and use to avoid cable damage. If a section of cable is damaged, it is recommended that you send your sensor back to replace the cable harness assembly.

End Connections: The contact areas (pins & sockets) of the connectors will wear out with extensive use. If your application requires repeated connections, other types of connectors can be provided. The connectors used by Seametrics are not submersible, but are designed to be splash-resistant.

Troubleshooting

Erratic Readings

Erratic readings can be caused by a damaged transmitter, damaged cable, poor connections or improper operation of readout equipment. In most cases, erratic readings are due to moisture getting into the system. Assuming that the readout equipment is working correctly, the first thing to check is the connection. Look for moisture between contacts or a loose or broken wire. If the connection appears OK, pull the transmitter up a known distance while monitoring its output. If the transmitter responds approximately as it should, but the reading is still erratic, most likely the cable is damaged. If the transmitter does not respond approximately as it should, it is most likely that the sensor is damaged. In either case, consult the factory.

Oscillating Readings Over Time

If, after time, your transmitter is functioning normally but your data is showing a cyclic effect in the absence of water level changes, you are probably seeing barometric changes. The amount is usually .5 to 1.5 feet of water. This can be caused by a plugged vent tube in the cable or actual water level changes in the aquifer itself in response to barometric pressure changes. This effect can occur in tight formations where the transmitter will immediately pick up barometric changes but the aquifer will not. If you think you are having this type of problem you will have to record the barometric pressure as well as the water level pressure and compensate the data. If it appears that the vent tube is plugged, consult the factory.

If a desiccant tube is not installed in line with the cable, water may have condensed in your vent tube causing it to plug. After you are finished installing the desiccant tube you can test the vent tube by applying a small amount of pressure to the end of the desiccant tube and seeing if this affects the transmitter reading.

Zero Readings When Pressurized

Continuous zero readings are caused by an open circuit which usually indicates broken cable, a bad connection, or possibly a damaged transmitter. Check the connector to see if a wire has become loose, or if the cable has been cut. If neither of these appears to cause the problem, the transmitter needs factory repair.

Technical Specifications

The EcoPRO submersible pressure transmitter represents the latest in state-of-the-art level measurement technology. This industry standard two-wire, 4-20 mA device offers improved noise immunity, thermal performance and transient protection. In addition to reverse polarity protection, under-current and over-current limitation are featured on both transmitter channels.

As mentioned above, the EcoPRO transmitter is a current loop device. This means that changes in pressure imposed on the stainless steel diaphragm result in proportional changes in current. The excitation source (DC supply or data logger) supplies the power but the transmitter actually controls how much current flows as long as the excitation specifications (e.g., voltage level) are met.

For a standard gauge pressure device, there is zero pressure on the diaphragm when above the surface of the liquid. This zero pressure is converted to a current flow of 4 mA. As the transmitter is lowered into the liquid, the amount of current that flows increases linearly (with increasing depth) to 20 mA when the maximum rated pressure (thus depth) is reached. That is, there is a straight line relationship between pressure (thus depth of submergence) and the amount of current that flows. A data logger therefore can apply power, measure the amount of current that is flowing and convert that to the depth of submergence using a multiplier and offset (m and b, respectively, for a $y = mx + b$ straight line) which are preset in the logger by the user.

Compute these m and b values as follows:

$$m = (\text{Total range of measurement in your units}) / 16 / 1000$$

For example: if you want to measure 0 – 15 psi:

$$15 / 16 / 1000 = .0009375$$

$$b = m * 4000 * (-1)$$

Using our 0 – 15 psi example above, this would be

$$.0009375 * 4000 * (-1) = -3.75$$

Component and Wiring Information

Transmitter Components

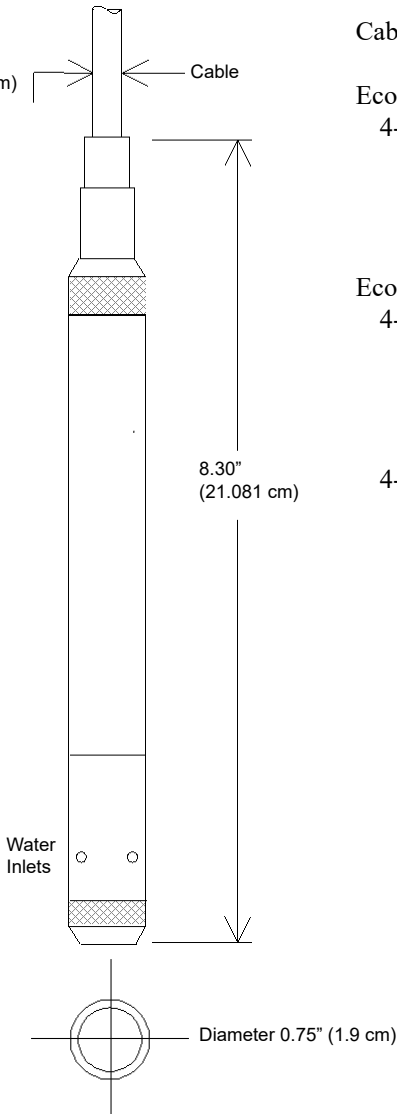

Wiring Information

Cable Type: 9-conductor, vented

EcoPRO

4-20 mA pressure only

Shield = ground

White = (V+) pressure

Blue = pressure signal return

EcoPRO+

4-20 mA pressure only

Shield = ground

White = (V+) pressure

Blue = pressure signal return

4-20 mA pressure and 4-20mA temperature

Shield = ground

White = (V+) pressure

Blue = pressure signal return

Yellow = (V+) temperature

Purple = Temperature signal return

Transmitter Components

Mechanical Specifications

TRANSMITTER

Body Material	316 stainless steel
Wire Seal Materials	Fluoropolymer and PTFE
Desiccant	High- and standard-capacity packs available
Terminating Connector	Available
Weight	.75 lbs. (0.3 kg)

CABLE

OD	0.28" (0.7 cm) maximum
Break Strength	138 lbs. (62.7 kg)
Maximum Length	2000 feet (610 meters)
Weight	4 lbs. per 100 feet (1.8 kg/30 m)

Electrical Specifications

PRESSURE

Transmitter Voltage	9-24 VDC, 100 ms warmup
Static Accuracy (B.F.S.L. 25° C)	±0.1% FSO (maximum) <i>(±0.25% for 1 PSIG, 2.3 FtH₂O, 0.7 mH₂O)</i>
Thermal Error (0-50° C, reference 25° C)	±2.0% FSO (maximum) ±0.8% FSO (typical)
Maximum Zero Offset at 25° C	±0.5% FSO
Over Range Protection	2x [except 300 PSIA (210 mH ₂ O)]
Compensated Temperature Range	0 - 50° C
Operating Temperature Range	-5° C to 70° C

TEMPERATURE (optional - EcoPRO+ only)

Transmitter Voltage	9-24 VDC, 100 ms warm-up
Output Range	0-50° C >> 4-20 mA
Accuracy (100 ms warm-up)	±0.75° C (maximum) ±0.3° C (typical)
Temperature Range	0 - 50° C
Operating Temperature Range	-5° C to 70° C

Adaptors

The following adaptors are available. Contact your Seametrics distributor for details and ordering information.

- 1/4" male NPT pipe fitting
- 1" male pipe adaptor
- 1" conduit adaptor

Reordering Information

For sales & service offices, please contact your distributor.

Accessories

- 7A40110 Desiccant Tube Replacement
- 7A50517 Strain Relief Kit
- 7A40413 Lightning Protection Module Kit



**Seametrics Incorporated • 19026 72nd Avenue South •
Kent, Washington 98032 • USA**

(P) 253.872.0284 • (F) 253.872.0285 • 1.800.975.8153 •

www.seametrics.com

LT-14238r1.3-20190610
6/10/2019