

### General Information

The FT520-84 is a version of the SeaMetrics flow processor specially designed for regeneration control. On the input side, it can be used with SeaMetrics flow sensors and meters, as well as contacting water meters from other manufacturers. The output can be used to initiate regeneration in a variety of one-tank and two-tank water treatment systems. In addition to the regeneration functions, this unit features displays of flow rate and accumulated flow, as well as programmable pulse output and a 4-20 mA analog output, for use with remote recorders.

There are two regeneration relays, which can be used for alternating regeneration of two tanks. The outputs remain on for a duration programmed by the user, depending on the requirements of the regeneration valve being used.

A programmable pulse output can be used as needed to control a chemical metering pump, for controlled chemical addition to the water stream.

### Specifications

<b>Power</b>	115/220 VAC, 50/60 Hz, 12-24 VDC
<b>Temperature Enclosure</b>	32° - 130° F (0° - 55° C) Precision cast aluminum, NEMA 4X
<b>Initiation Outputs</b>	Two Form C SPDT relay, 115 VAC 5A max
<b>Max Pulse Output</b>	100 mA at 60 VDC
<b>Memory Type</b>	Non-volatile EEPROM auto-backup
<b>Sensor Power Totalizer</b>	12 VDC, 10 mA 8 digit
<b>Rate Display</b>	5 digit
<b>Volume Units</b>	Gallons, cubic feet, cubic meters, liters, million gallons
<b>Output Time</b>	1-999 Seconds
<b>Analog Output</b>	4-20 mA, 0-10 VDC, opto-isolated
<b>Sensor Input</b>	Open collector current sink, ESD protected
<b>Max Input Frequency</b>	1,000 Hz
<b>Shipping Weight</b>	7 lbs

### Features

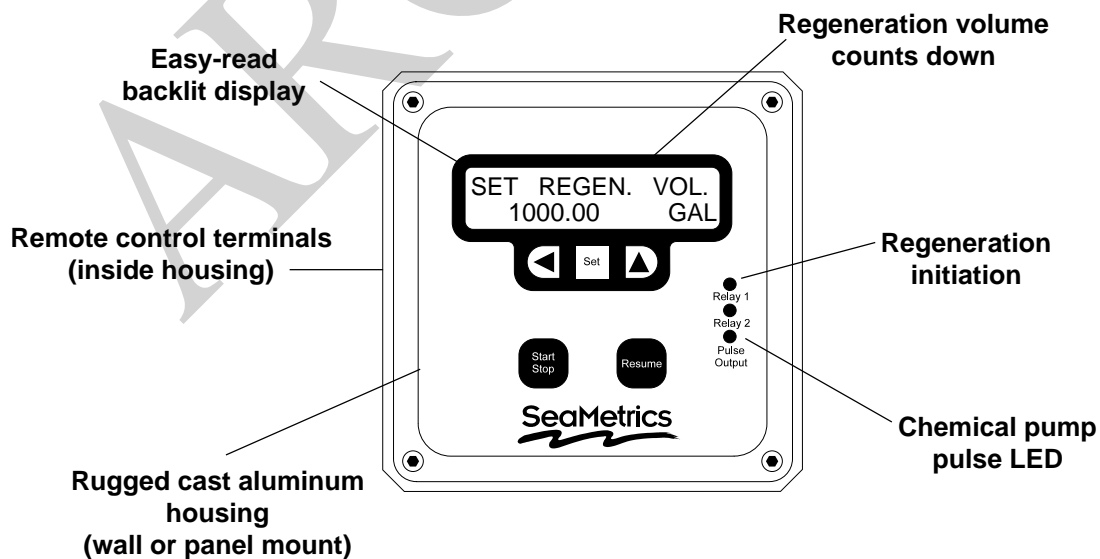

## Installation

**Wall Mounting.** Using the eight screws provided, attach the two foot brackets to the sides of the enclosure. Then attach the unit to any secure surface by inserting screws through the mounting holes in the foot brackets.

**Panel Mounting.** Follow the dimensions for “Panel Cutout” to cut a hole in the panel. Slide the panel mount gasket up from the bottom of the enclosure to its place behind the panel mount flange. Insert the unit through the panel cutout. Install the two panel mount brackets on the sides of the unit using the eight screws provided. Each bracket has one threaded center hole. Insert and tighten one screw in each hole, until the flange is pulled firmly up against the panel and the gasket is compressed.

**Expose Terminals.** Remove the four screws which hold the front plate to its flange. Remove the front plate. The display board is attached to this front plate. It is also connected to the power board by a ribbon cable. For convenience, this cable can be disconnected, or the display board can be allowed to dangle while making connections. Connections can be made inside the enclosure, or the terminals can be unplugged for easier access, by gently tugging on them.



**Caution:** When the control is powered up, relay or analog outputs may be present. If this could be a hazard, wait to make external connections until programming is complete.

**Sensor Connection.** Follow the “Connections” diagram to connect either two or three wires from the flow meter or flow sensor.

**Regeneration Valve Connection.** Connect the leads which initiate the regeneration valve(s) to the terminals marked Relay 1 and Relay 2. (See “Connections” diagram.) If only one unit is being connected, use Relay 1. (Relay 2 will operate only if “Alternate Relays” mode is being used.)

**Power Connection.** Connect AC or DC power as desired to the appropriate terminals. For safety, if using AC power, be sure to connect the ground terminal provided to a good earth ground.

Replace the front panel, taking care to reconnect the ribbon cable if it has been disconnected. When power is switched on, the display should light up immediately with meaningful letters or digits.

## Displays

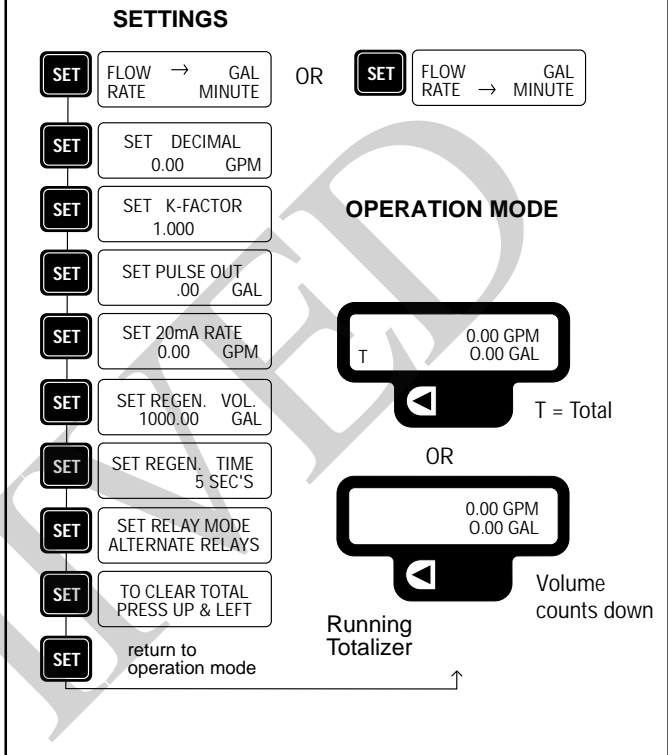

## Settings

**Set Flow Rate.** Use to select volume units. Use to select the particular unit desired (gallons, liters, etc.). Then use to switch to time units. Again, select the one desired.

**Set Decimal.** Use to select zero, one, or two decimal places on the flow units.

**Set K-Factor.** The unit will not function properly until this number is entered. It is simply the number of pulses which the flow meter or flow sensor puts out per gallon of liquid. It is marked on the Model/Serial tag of SeaMetrics flow meters and flow sensor fittings. On adjustable flow sensors, the K-factor must be taken from the chart in the flow sensor instructions, based on pipe size. Set the number with keys. The digit which is underlined is the one being set. The moves one digit to the left. The increases the digit. When the appropriate number has been set, press again to move on to the next menu item.

**Set Pulse Out.** An output pulse is activated at the selected volume intervals if this feature is in use. Otherwise, it does not need to be set.

**Set 20 mA Out.** A 4-20 mA analog output is standard on this unit. If a 4-20 mA current loop is connected, set the flow rate, in the desired units, at which the peak 20 mA is desired. The controller will automatically scale the 4 mA output to zero flow.

**Set Regeneration Volume.** This is the volume (in the units you have selected, typically gallons) at which the relay energizes to initiate a regeneration cycle. Set to the desired amount using the ◀ and ▶ keys.

**Set Regeneration Time.** This is the length of time, in seconds that the relay remains energized to initiate regeneration. Using the ▶ key, set for a bit over the minimum time required by the regeneration valve to begin a cycle.

**Set Relay Mode.** Choose between single relay (Relay No. 1) and dual relay (Alternate Relays) operation, using the ▶ key. In alternate relay mode, the first regeneration will use relay 1, and the next will use relay 2, and so on.

**Clear Total.** This function resets the running total back

to zero. It is unrelated to the regeneration function, and can be ignored unless it is needed. To reset to zero, press ▶ and ◀ simultaneously, as instructed.

## Operation

**Choice of Displays.** When all of the settings have been entered, the next press of the Set key puts the unit in operation. If a T appears at the left side of the display, the values shown are flow rate and running total. If there is no T, the values shown are flow rate and units remaining until regeneration. The total increases with flow, and the regeneration quantity counts down. Use the ▶ key to choose the preferred display, usually regeneration quantity.

**Regeneration Initiation.** When the regeneration quantity number first reaches 0, relay 1 energizes for the length of time which has been set. The regeneration quantity immediately resets to its setting and begins counting down again. If alternating mode has been selected, the next time it reaches 0, relay 2 will energize, and the cycle after that returns to relay 1.

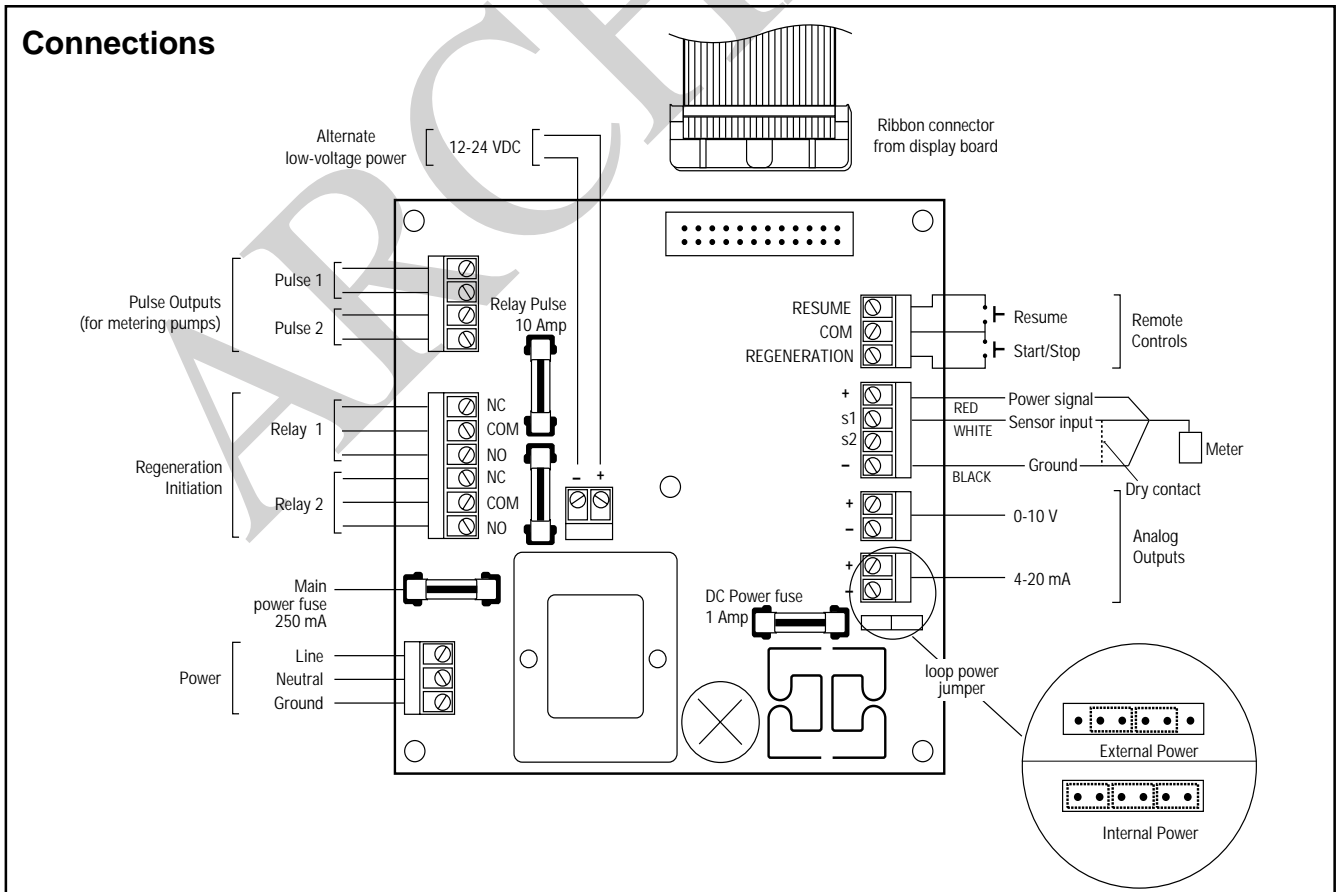

An output can be manually forced at any time by pressing the Start/Stop key. The relay will energize for the set time, and regeneration volume will return to its original setting to begin counting down again.

## Repair

The only field-repairable component on the FT520 is the fuse. If failure is due to a cause other than a blown fuse, it is necessary to replace the entire board stack. Contact your distributor for information.



**Caution: Always disconnect power to the unit before opening the terminal cover. Do not reconnect power until all connections have been made and the terminal cover has been replaced.**

**Fuses.** The power supply and the analog output circuit have fuse protection. The two fuses are on the board. Replace the blown power fuse with a 250 mA, 5x20 mm glass fuse, available from SeaMetrics or from Radio Shack (or other electronic supply store). The DC power fuse is a 1 Amp, 5x20 mm glass fuse.

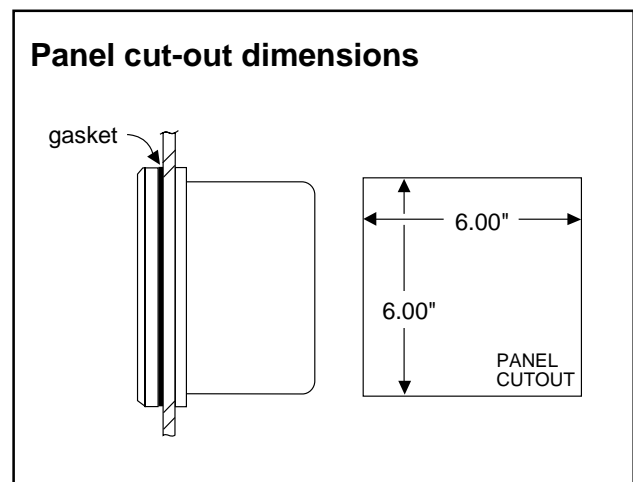
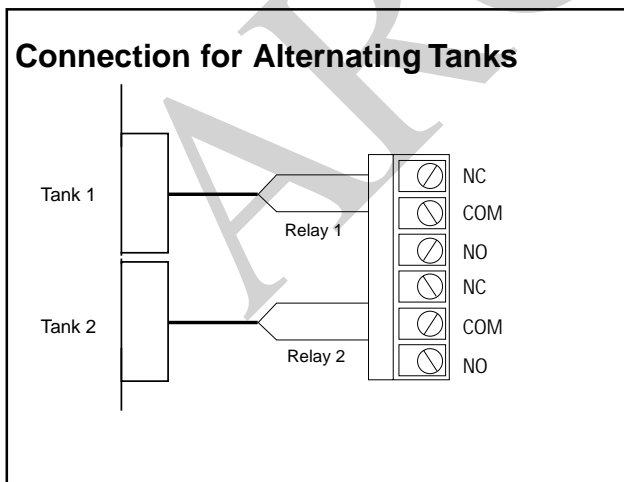
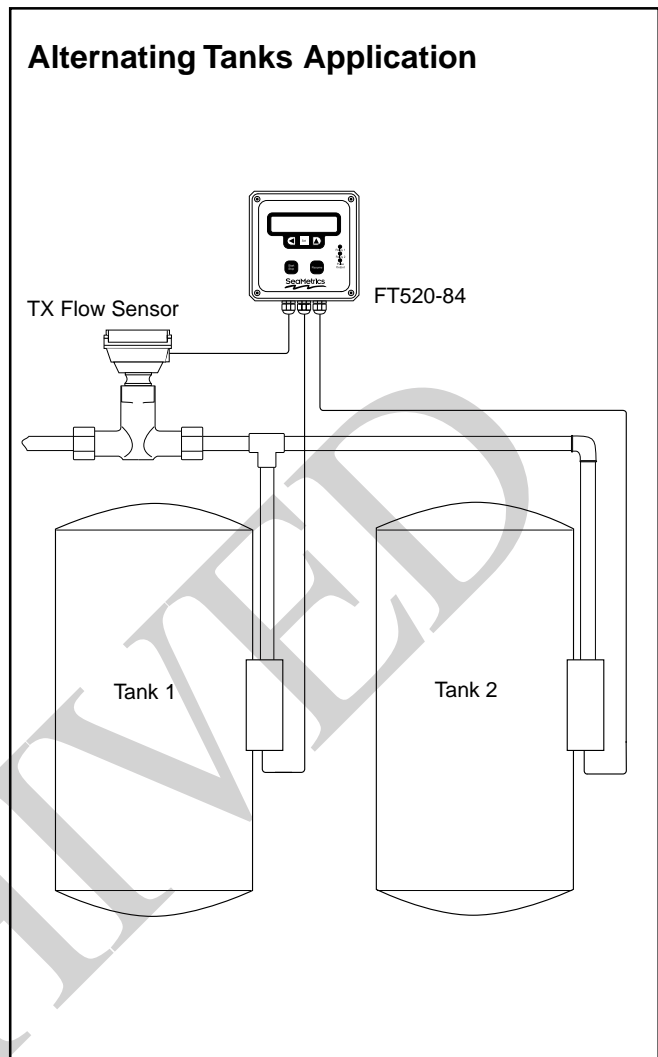

20419 80th Ave. So., Kent, WA 98032 USA  
 Phone: 253-872-0284 Fax: 253-872-0285  
[www.seametrics.com](http://www.seametrics.com) 1-800-975-8153