

Description

Nearly all flow meters must be installed so that there is a significant run of straight pipe before and after the location of the flow meter. This is intended to allow the straight pipe run to "smooth out" any turbulence produced by the presence of valves, thermowells, chemical injectors and diffusers, and changes in pipe direction. This type of turbulence produces error in the the reading of most flow meters.

How Much Can The Error Be?

The error can be quite large. The error produced by a thermowell installed immediately upstream of a flow meter can be in the range of 5-10%. That of a gate valve or a butterfly valve can be as much as 50-60%! The error produced from a partially closed ball valve can be as much as 50%, too. Chemical injectors can produce significant error also. For example, a chlorine injector-diffuser may produce enough entrained undissolved chlorine bubbles to produce an error in the 10-20% range.

Good Installations

Seametrics suggests at least 10 diameters of straight pipe run upstream and 5 diameters of straight pipe run downstream of the flow meter installation in order to achieve proper accuracy. These are minimum values. As the diagrams on the the next page will show, you may need much more straight run under specific circumstances.

Preventing Cavitation

Cavitation can be caused by entrained air, and it can seriously damage the rotor on a turbine or paddlewheel flow meter. An amount higher than about 100 mg/l of entrained air or gas can produce error. In addition, cavitation can be caused by too little backpressure on the flow meter. For turbines and other rotary impeller flow meters, you should provide a backpressure (downstream pressure) of at least 1.25 times the vapor pressure, plus 2 times the pressure drop through the meter. This can usually be accomplished by providing the minimum downstream straight run prior to discharge.

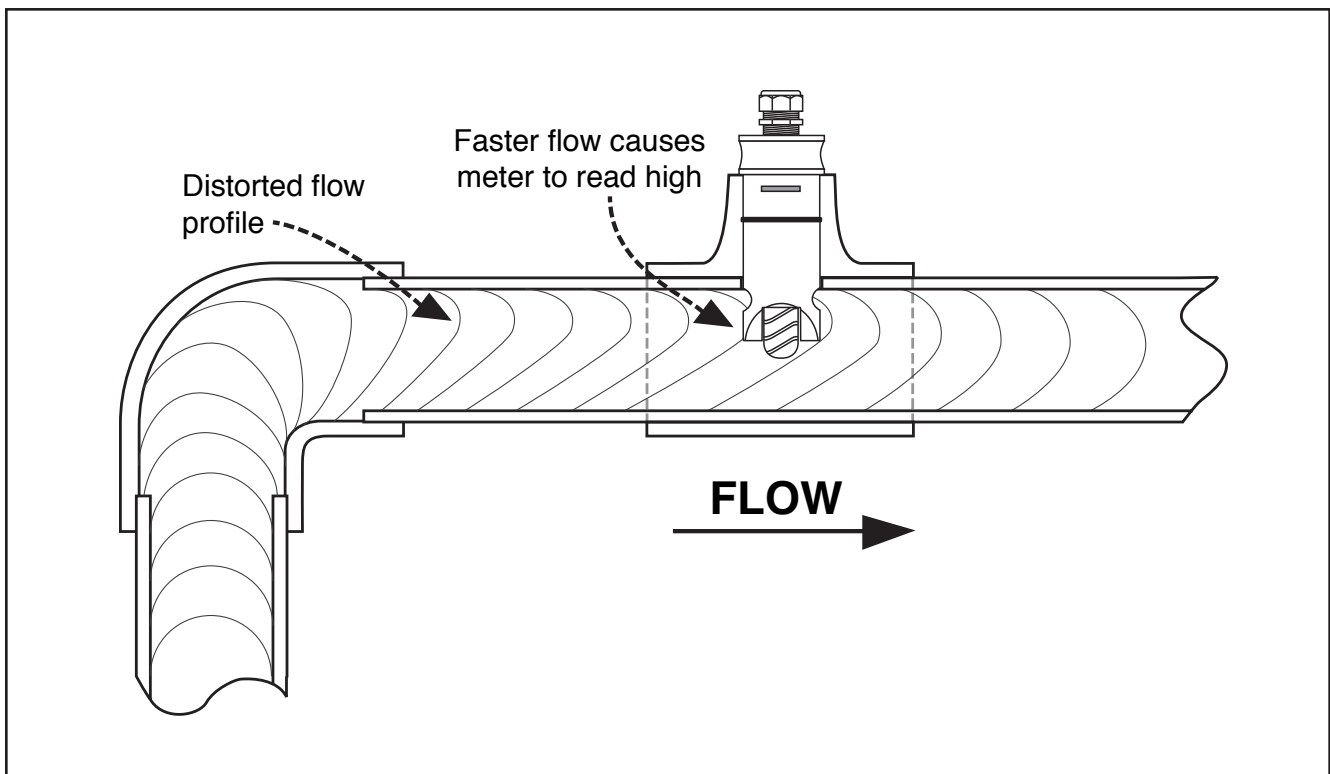

When In Doubt, Straighten The Flow

There are a number of ways to straighten the flow. Flow straighteners are included in Seametrics carbon steel and stainless steel WT series turbine flow meters and in our WP meters also. If you need the highest possible accuracy from your flow meter installation, you should install a separate flow-straightening device upstream of the flow meter. Seametrics recommends Vortab® flow straightening devices because of their accuracy and low pressure-drop. Any flow straightener requires additional diameters of straight run. Usually the minimum requirement is 7 diameters before the flow straightener and 5 diameters between the straightener and the flow meter itself. Using a flow straightener is not a substitute for correct amount of straight pipe run!

What If You Can't Provide Adequate Straight Run?

If you can't provide enough run to smooth out the turbulence caused by valves, fittings, and changes in direction, you will have to live with the inaccurate effects this turbulence will create. This does not mean that the flow meter's reading is meaningless, however. In the majority of applications, it may be enough to provide a repeatable reading, if not an accurate one. In applications where the flow meter is a control device, operating a valve or controlling chemical addition, repeatability of reading is more critical than absolute accuracy. You may find that you can get excellent results without excellent accuracy.

Some Rules of Thumb

To the right are several diagrams with some recommendations to assist you in properly locating your Seametrics flow meter. Remember these are only Rules-of-Thumb. If you **do** experience error in spite of observing these recommendations, you may be able to perform an "on site" calibration to attempt to minimize the error. Consult with Seametrics prior to doing this, so we can advise you on appropriate methods, and potential results.

