

Technical Bulletin

Attaching Neoprene Pads to FT430/440/450



Purpose

In order to keep distributors and end users informed of potential operational, accuracy, and ease of use issues, Seametrics is issuing the following Technical Bulletin

Product

FT430, FT440, and FT450

Symptom

Display goes blank or some of the characters are corrupted

Serial Numbers Affected

(The first 2 digits of a serial number represent the month and the next four represent the year)

Serial numbers starting with 072015 through serial number 042016002000

This problem is resolved but units in the date range may be affected.

Suggested Field Repair

Step 1

Remove 4 torx head screws, using T-15 torx head driver.

Step 2

Remove the printed circuit board. (Board should be free to remove once the torx head screws have been removed.)

Step 3

Clean surfaces (as marked) with isopropyl alcohol or equivalent.

(continued on next page)



Caution: This operation should be performed using ESD sensitive methods.

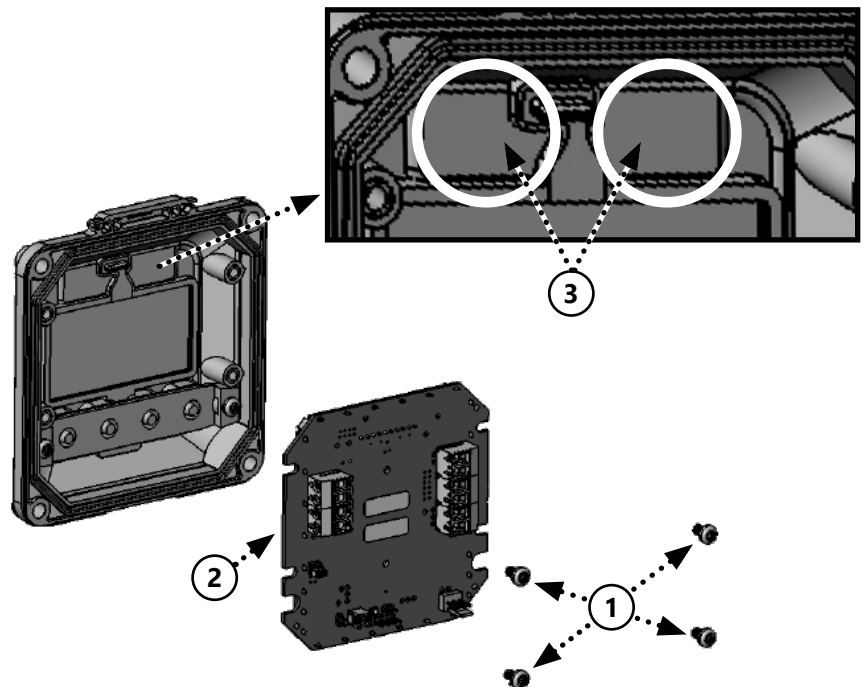

Step 4

Attach neoprene pads (P/N 103693), as shown. *(If you do not already have a set, contact the factory and a set of neoprene pads will be provided at no charge.)*

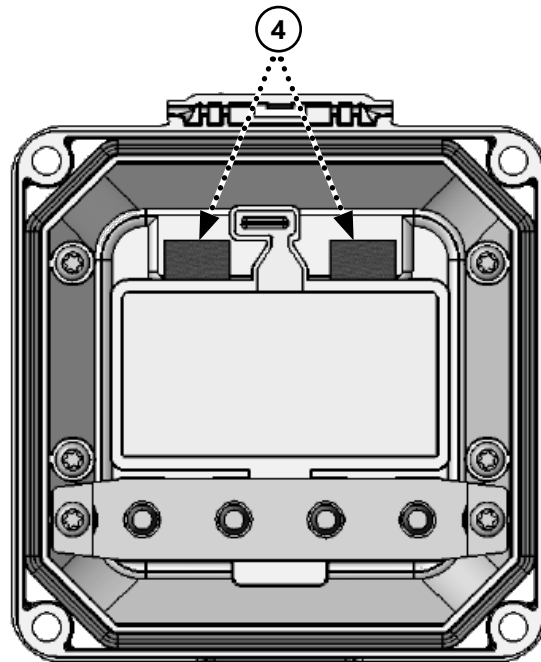

Step 5

Reinstall printed circuit board and hold in place while reinstalling the 4 torx head screws. Screws should be snug but not over tightened.

