

### General Information

The SeaMetrics AO45 is a compact pulse to analog converter. Combined with an IP insertion flow sensor or a WT turbine meter, it is ideal for flow rate recording, PLC or data logger input, and proportional chemical feed. The unit is available in a wallmount enclosure or in a round cast-aluminum housing mounted directly on a SeaMetrics meter. The nonmetallic wallmount enclosure is splash-proof and has a clear cover.

The 4-20 mA analog output is suitable for telemetry, metering pump pacing, data logging, or control applications. Trimpots are used to adjust the 4 mA and 20 mA setpoints. The unit can be factory-calibrated or user calibrated with the proper equipment. The output is a 4-20 mA current source, which is compatible with electronic metering pumps, programmable controllers and computer input cards.

### Specifications

<b>Power</b>	
Sensor	6-24 VDC
Current loop	12-36 VDC (see chart)
Voltage Burden	11 VDC
<b>Temperature</b>	32° - 130° F (0° - 55° C)
<b>Humidity</b>	85% non-condensing relative
<b>Enclosure</b>	
Wall mount	polystyrene
Meter mount	cast aluminum
<b>Input</b>	Open collector transistor (most SeaMetrics meters)
<b>Frequency range</b>	(@ 20 mA output)
Low	10 - 100 Hz
High	100 - 1000 Hz
<b>Output</b>	Proportional 4 - 20 mA
<b>Response Time</b>	3 sec. to 95 % output

### Features

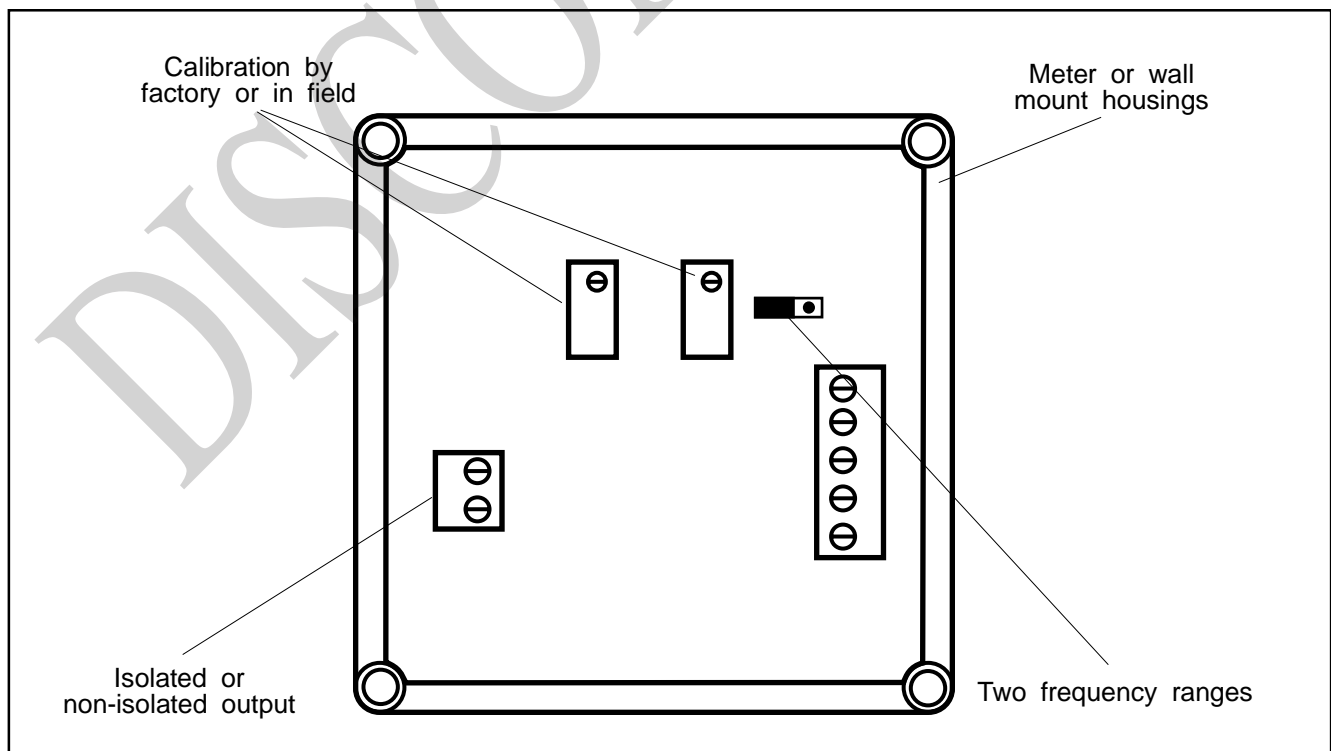

## Installation

**Mounting.** Only the wall mount (W) housing style needs to be mounted. The meter mount (M) unit comes preinstalled on a flow meter or sensor. To mount the W housing, remove the front cover. Locate the screw holes underneath the four cover screw holes. Mark the centers and drive screws through these holes into a secure surface. It is important to use only these holes, which are isolated from the interior of the enclosure, in order to keep the enclosure leaktight.

**Connections.** See the "Connections" diagrams on page 4. Determine whether or not the 4-20 mA output needs to be isolated:

1. If the external 4-20 mA device has its own built-in power supply, follow the "Isolated power source" diagram.
2. Isolation prevents certain potential problems, such as ground loops. It also allows a higher voltage to be used for the 4-20 mA loop (up to 35 VDC) to drive a higher-impedance load, roughly above 300 Ohms. Typically the literature provided with the 4-20 mA device will specify its impedance.

3. A non-isolated circuit is simpler because it only requires one power supply. As a general rule, the standard SeaMetrics PC1 power supply can power both the control and the 4-20 mA loop up to 300 Ohms impedance.

The connection for AO45M meter mounted units as supplied is non-isolated, with a jumper wire preinstalled to power the 4-20 mA loop. If an isolated connection is necessary, unscrew the cover and remove the circuit board to expose terminals. Reconnect the unit following the "Isolated power source" diagram.

For a wall mount unit, connect the flow sensor first. Then connect the 4-20 mA output, following the appropriate diagram. Finally, connect the power supply.

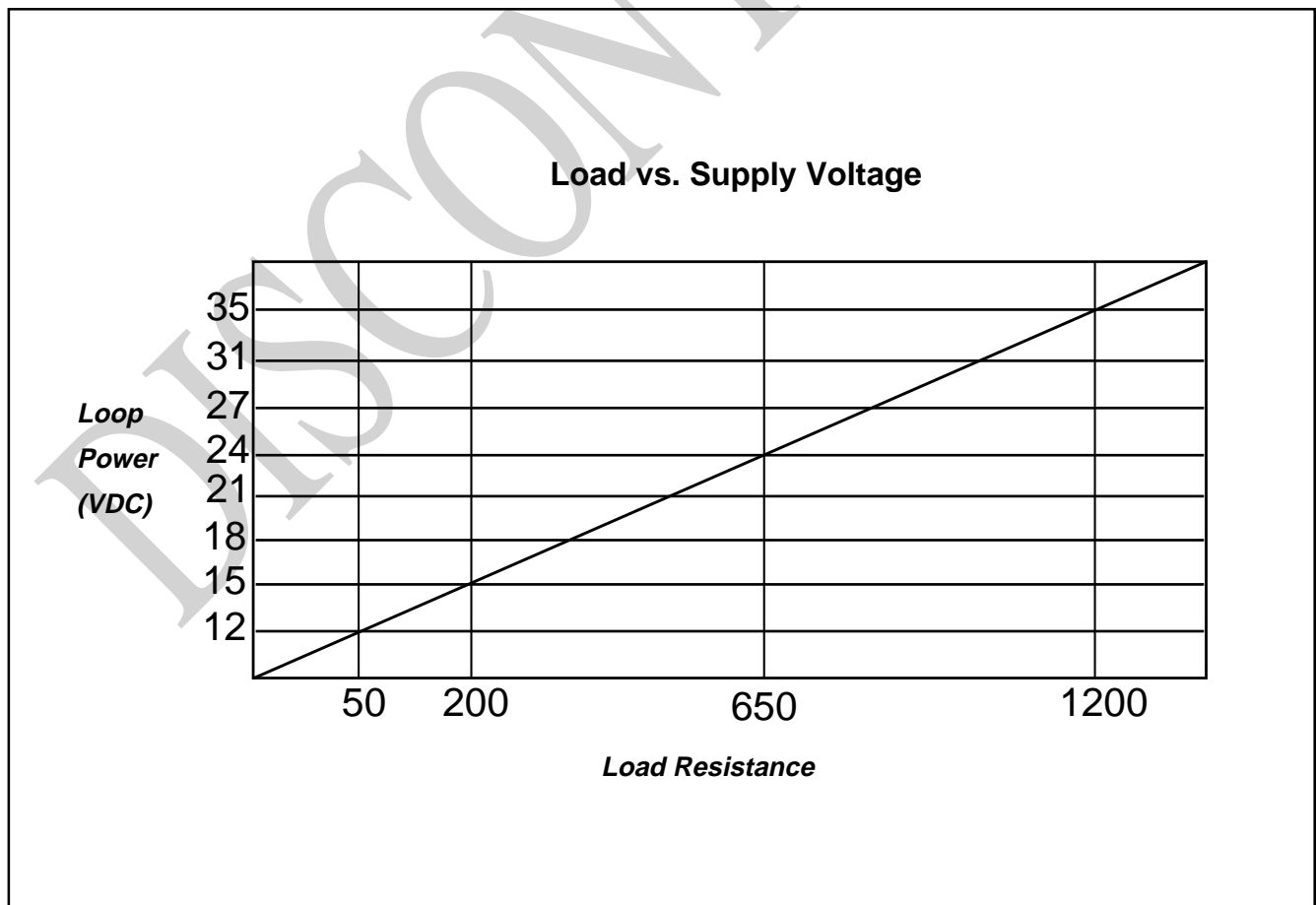

**Field Calibration.** Ordinarily the AO45 is ordered with a flow sensor or meter and is factory calibrated to a requested flow range. However, the unit can be field-calibrated if necessary. A frequency generator and a multimeter are required. Follow these steps:

1. *Calculate 20 mA frequency.* Determine the flow rate at which 20 mA output is desired. Determine the K-factor (pulses per gallon) of the flow sensor. For SeaMetrics units, this is marked on the sensor. Use this formula:

$$\text{Frequency} = \frac{\text{K-factor(PPG)} \times \text{Flow Rate(GPM)}}{60}$$

2. *Select range.* There are two frequency ranges, 10 - 100 pulses per second and 100 - 1,000 pulses per second. Note the range into which the calculated 20 mA frequency falls.

Find the frequency jumper. Choose position HI or LO and place the jumper there.

3. *Connect multimeter.* Set the multimeter for mA and connect to the 4-20 mA terminals, observing polarity. Apply power.

4. *Adjust 4 mA.* Locate the trimpot marked "4 ADJ". Dial the pot until your multimeter reads 4.00 mA.

5. *Connect frequency.* Set your frequency generator for the 20 mA frequency as calculated above. Connect to the input terminals marked "SENSOR" and + 12 V.

6. *Adjust 20 mA.* Dial the trimpot marked "20 ADJ" until your multimeter reads 20.00 mA. Disconnect the multimeter. Calibration is completed.

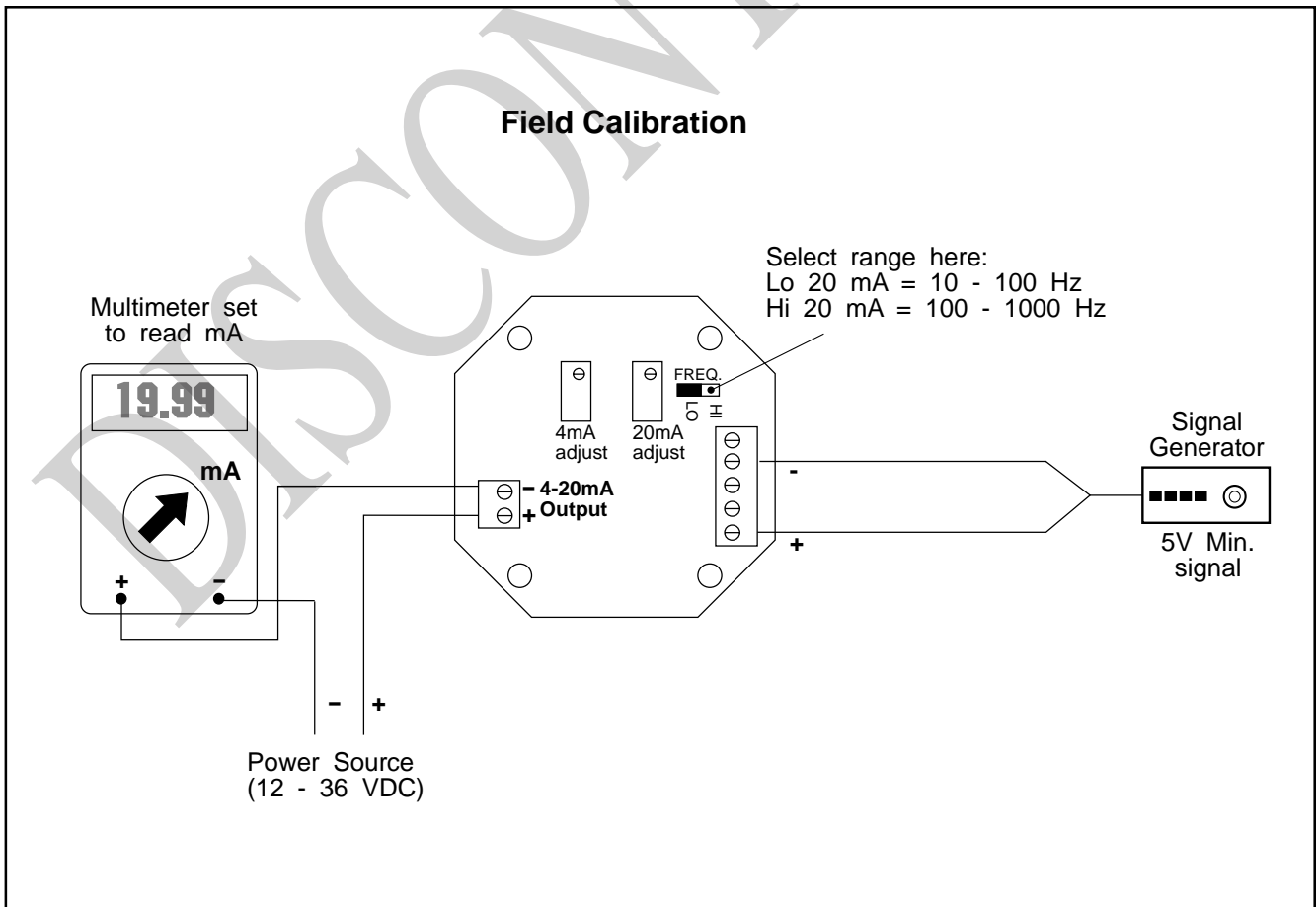

### Connections: non-isolated loop power (standard factory wiring)

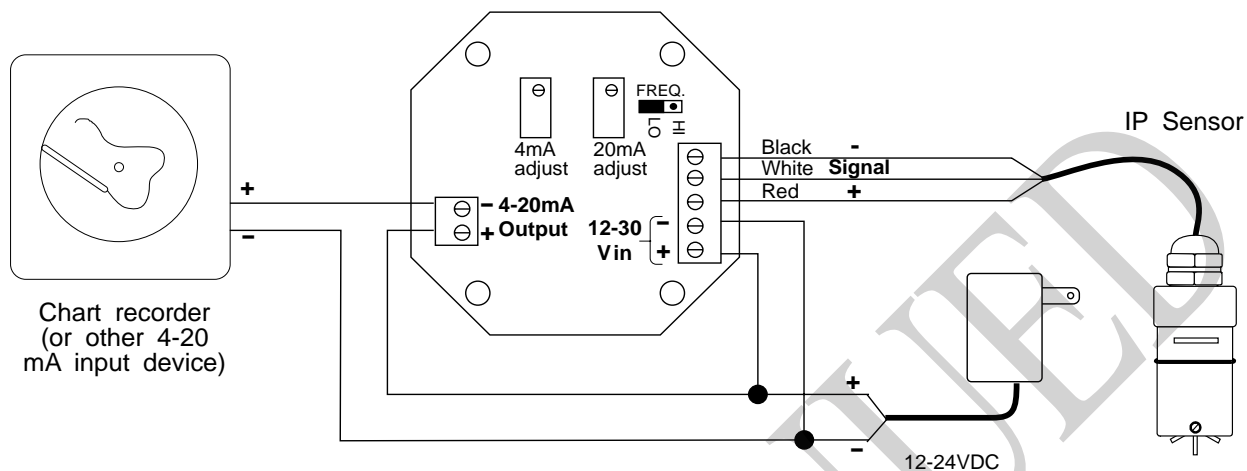

### Connections: isolated loop power

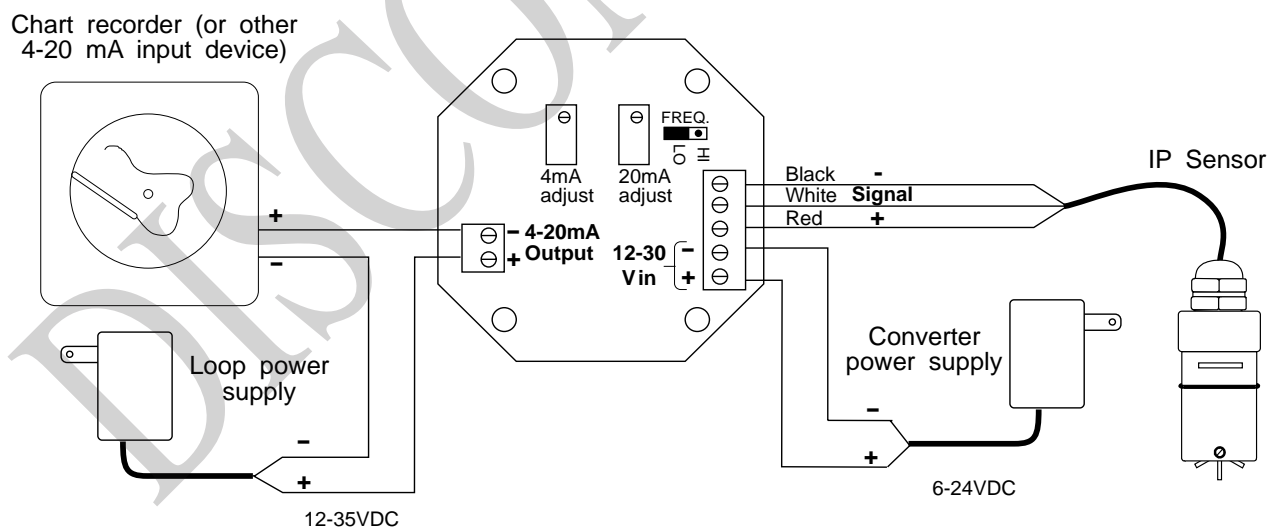

**SeaMetrics**

20419 80th Ave. So., Kent WA. 98032 USA  
 Phone: 253-872-0284 Fax: 253-872-0285  
[www.seametrics.com](http://www.seametrics.com) 1-800-975-8153