



FEATURES

- Single or dual power supply
- Rugged plastic housing
- Wall, panel, or outlet mounting styles
- 24 Vdc and 12 Vdc, depending on model

APPLICATIONS

Power supplies for:

- Flowmeters
- Indicators and controllers
- 4-20 mA loop devices
- Magmeter/indicator combinations



PC42



PC2



PC3

GENERAL INFORMATION

Seametrics offers a selection of power supplies for use in a variety of applications. The appropriate power supply is chosen based on the power requirements of the specific component(s) in the application as well as the desired mounting style.

Model	Power	Regulation	Mounting
PC2	24 Vdc	regulated	Panel
PC3	24 Vdc	unregulated	Outlet
PC42	Dual 24 Vdc and 12 Vdc	regulated	Wall or Panel

The **PC2** is a single 24 Vdc regulated power supply designed for panel mounting.

The **PC3** is a single 24 Vdc unregulated power supply that

plugs into a 120 Vac outlet. Since it is unregulated, voltages can vary up to approximately 32 Vdc depending on the load. The PC3 should be used only in applications where these voltages are tolerated.

The **PC42** is a regulated dual power supply (12 Vdc and 24 Vdc) for use in applications where a magmeter is used along with a 4-20 mA transmitter. Though a single power supply can work in such applications, the PC42 eliminates the risk of potential ground loop interference. The PC42 is designed for wall or panel mounting.

PC42

The PC42 dual power supply is designed for applications in which a magmeter is used together with a 4-20 mA transmitter such as the A055 or FT420. Although a single 24 Vdc power supply can be used, there is a risk of a ground loop interfering with proper operation of the 4-20 mA current loop. This risk is eliminated by the dual power supply.



The housing is rugged molded ABS plastic, NEMA 4X rated. It can be wall or panel mounted. The PC42 can be hardwired to the AC main supply or plugged into a standard outlet using the included power cord. Inside there are separate terminals to connect the two devices to the fully isolated supplies.

SPECIFICATIONS*

Input Power	115 Vac/230 Vac internally switchable
Output Voltage/Current	12 Vdc output +/- 1% @ 350 mA 24 Vdc output +/- 4% @ 100 mA
Terminal Block Wire Size Range	22 - 12 AWG
Dimensions	4.93" L x 4.93" W x 2.92" H (125 x 125 x 74mm)
Operating Temperature	-20° to +60° C
Environmental	NEMA 4X

*Specifications subject to change • Please consult our website for current data (www.seametrics.com).

INSTALLATION and CONNECTIONS

Remove the cover to expose the four mounting holes at the bottom of the cover screw tubes. Mark the mounting surface, drill, and attach with screws. **Do not drill additional holes in the box.** Doing so will allow moisture into the enclosure.



Caution 1: Important! Do not connect power to the PC42 until all connections have been made and confirmed correct, and the cover has been put back into place.

Caution 2: It is essential for safety and proper operation to use a ground connection for the 115 Vac power. Do not use this power supply without proper grounding.

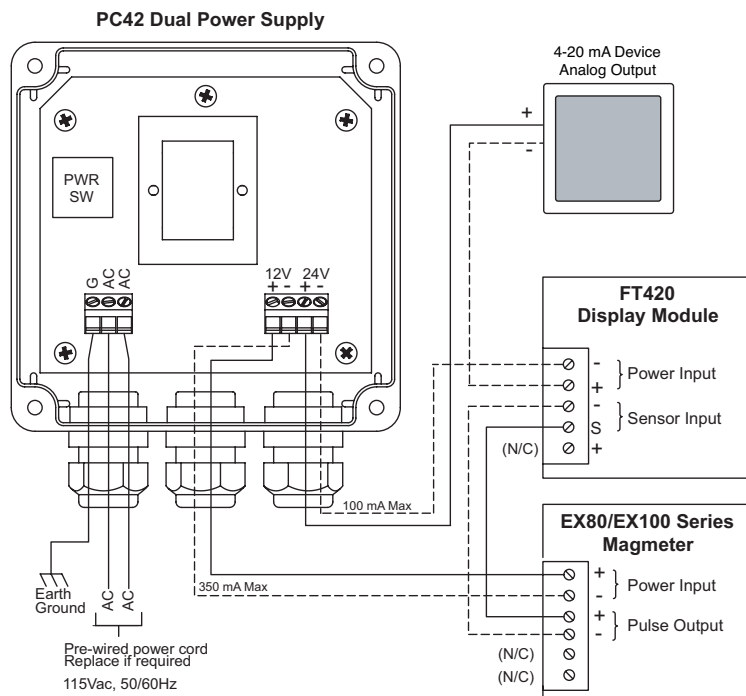

DIMENSIONS

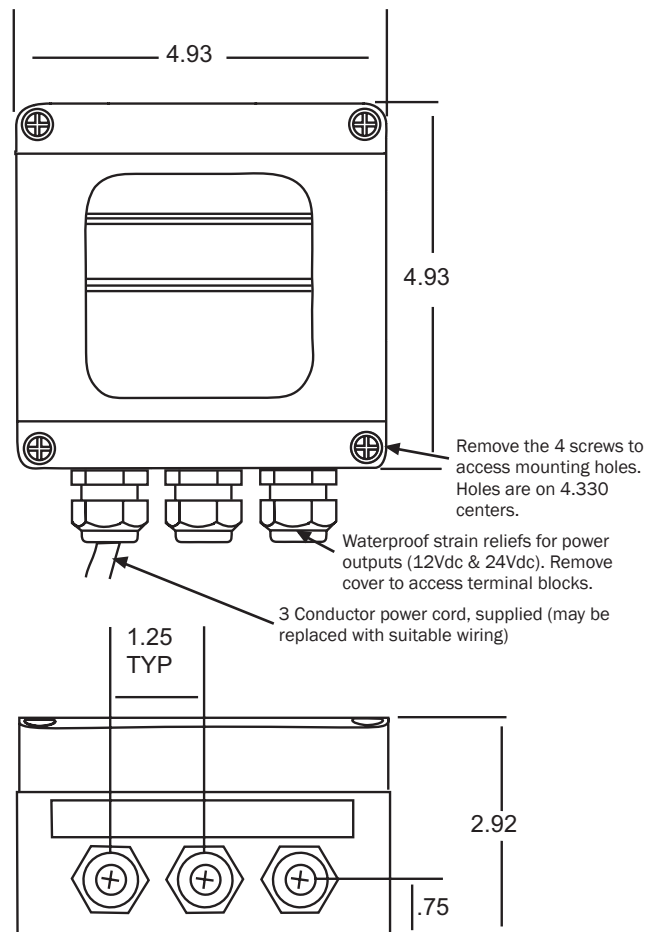



PC2

The PC2 is a screw-terminal single power supply, designed for use in the protected environment of a panel or enclosure. This compact unit is regulated at 24 Vdc and is well-suited for powering a 4-20 mA loop.

SPECIFICATIONS*

Input Power	115 Vac/60 Hz (external fuse recommended)
Output Voltage/Current	24 Vdc +/- 1.0 Vdc @ 100 mA
Regulation	+/- 1.0% (line and load)
Ripple and Noise	1 mV RMS
Screw Terminal Size	22 - 14 AWG
Dimensions	2.99" L x 2.20" W x 1.40" H (76 x 56 x 35.5 mm)
Operating Temperature	0° to +55° C

*Specifications subject to change • Please consult our website for current data (www.seametrics.com).

DIMENSIONS

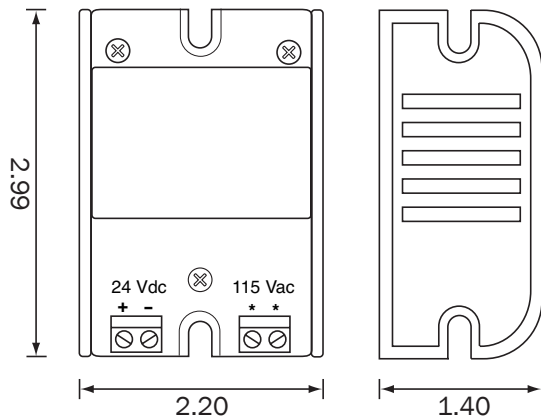

TYPICAL APPLICATION

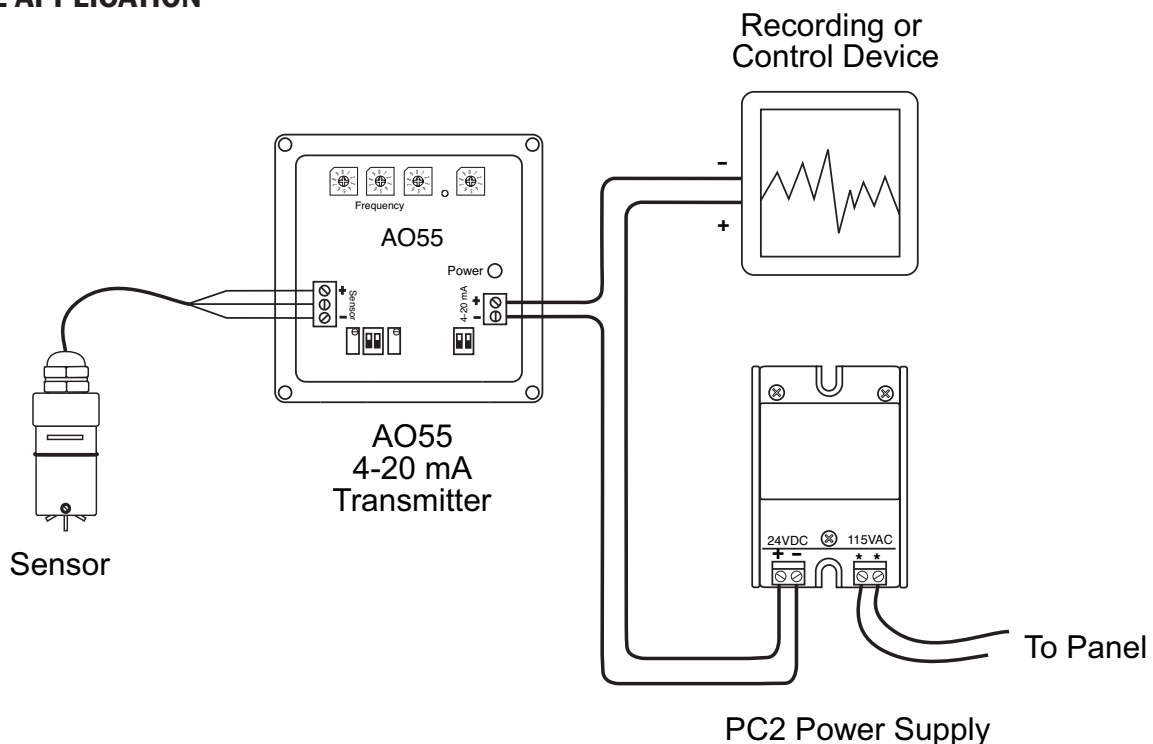



PC3

The PC3 is designed as a convenient 24 Vdc power supply for use with a 120 Vac outlet. Terminals allow user connection of wiring on the low-voltage side. Since this is an unregulated power supply, actual voltage may be as high as 32 Vdc, depending on load.

SPECIFICATIONS*

Input Power	120 Vac, 60 Hz, 19 W
Output Voltage/Current	24 Vdc @ 500 mA
Regulation	Unregulated; may vary up to 32 Vdc
Screw Terminal Size	22 - 18 AWG
Dimensions	3.23" L x 2.20" W x 1.93" H (82 x 56 x 49 mm)
Operating Temperature	0° to +60° C
Safety Agency Approvals	UL, C-UL (Canada) listed

*Specifications subject to change • Please consult our website for current data (www.seametrics.com).

DIMENSIONS

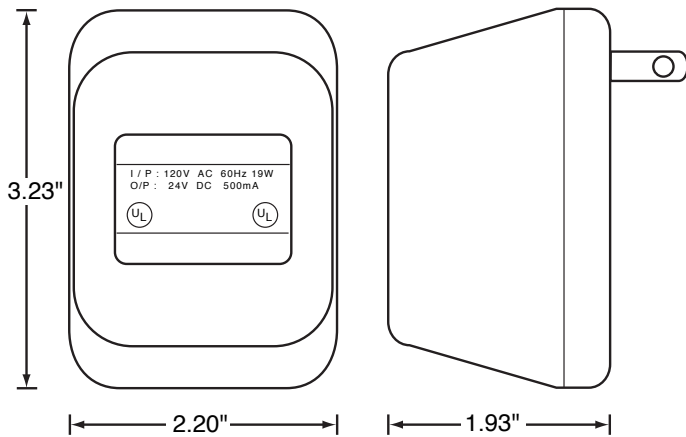

TYPICAL APPLICATION

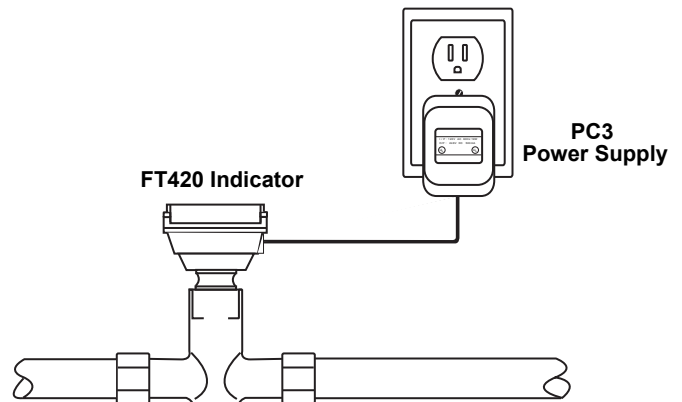

HOW TO ORDER

MODEL

Single 24 Vdc, regulated, panel mount = **PC2**

Single 24 Vdc, unregulated, outlet = **PC3**

Dual 12/24 Vdc, regulated, wall or panel mount = **PC42**

CONTACT YOUR SUPPLIER