

**TURBINE METER
INSTRUCTIONS**



GENERAL INFORMATION and SPECIFICATIONS

GENERAL INFORMATION

WJ-Series turbine meters are dry-register mechanical totalizers that offer accurate, economical reading of high flows with low pressure loss. The horizontal-axis turbine drives a vertical shaft, which is magnetically coupled to the sealed register.

In addition to mechanical totalizing, registers can be equipped with magnetic pulse reed sensors well suited for remote totalizing, pacing of electronic metering pumps, and water treatment applications.

Bodies are manufactured of tough cast iron and epoxy-coated for protection. Tungsten steel shafts and jewel bearings further enhance the durability of these meters. Simple removal of the top flange brings out all parts for inspection, repair, or replacement. The meter has a tamper-evident seal to call attention to unauthorized access.

Compatible Seametrics controls include the PT35 pulse timer, the PD10 pulse divider, and the PS40 pulse splitter for running multiple pulse-responsive devices (e.g. pumps, counter timers and remote totalizers) with a single WJ meter.

FEATURES

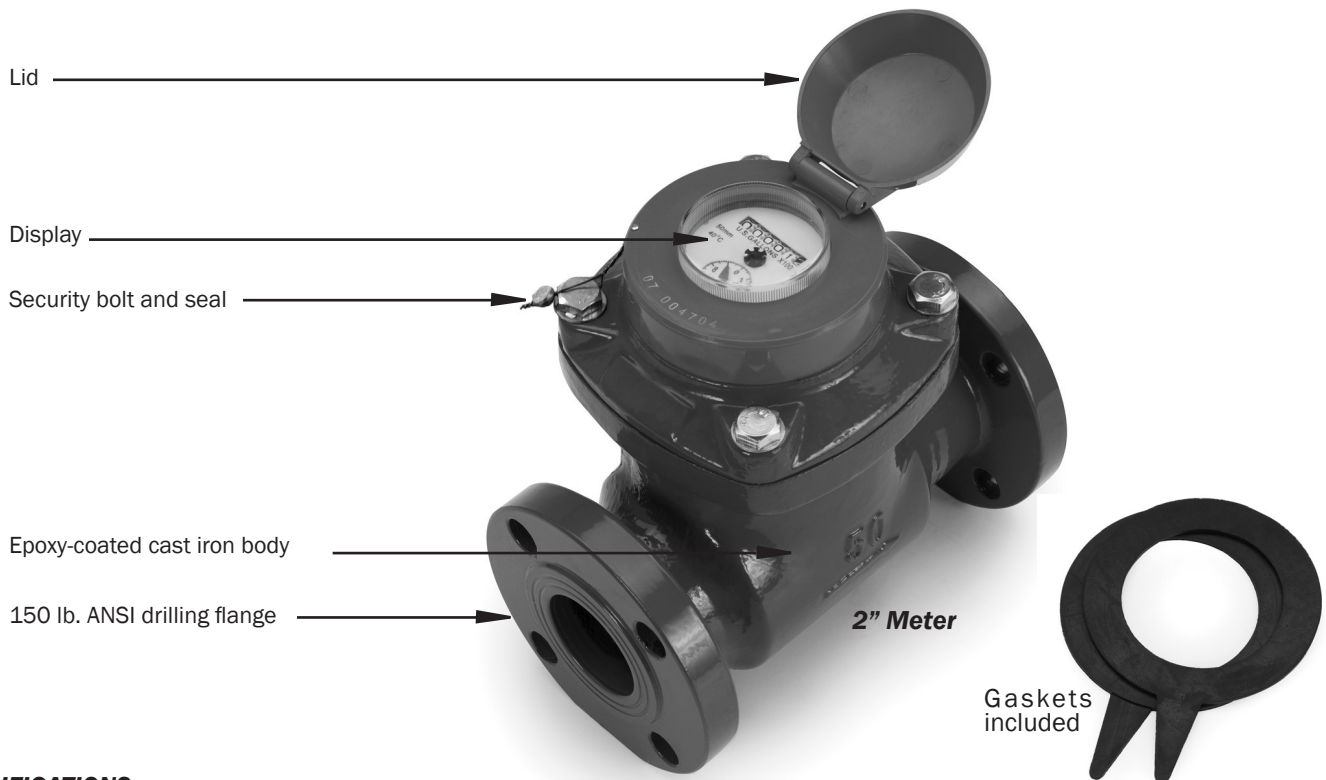

SPECIFICATIONS

Materials	Meter Body	Cast iron, epoxy coating
	Register Plate	ABS plastic
	Drive Magnet	Alnico
	Turbine	Plastic
	Turbine Shafts	Tungsten steel
	Bearings	Jewel
Flanges		150 lb. ANSI drilling
Maximum Pressure		200 psi (14 bar)
Maximum Temperature		105° F (40° C)
Accuracy*	Above Transition	+/-2% of reading
	Below Transition	+/-5% of reading
Reed Switch		100 mA @ 24 Vac/dc

*Specifications subject to change • Please consult our website for current data (www.seametrics.com).

FLOW RANGE (GPM)

	2"	3"	4"	6"	8"
Minimum	2	5.3	8	20	33
Max. Continuous	132	352	528	1320	2200
Max. Intermittent	165	440	660	1650	2750
Transition*	16	24	40	80	140

*The flow rate at which accuracy changes from +/-2% of reading (above Transition) to +/-5% of reading (below Transition).

INSTALLATION

The following installation recommendations are adapted from the American Water Works Manual M6, and will result in the best meter life and accuracy.

Piping Conditions. It is recommended that the meter be installed with at least ten diameters of straight pipe upstream and five diameters downstream from elbows, tees, crosses, valves, and other fittings. If less straight pipe is available, or if debris are likely to go through the meter, installation of a standard plate-type strainer directly upstream is recommended. If a basket-type strainer is used, it should be located at least five diameters upstream. Avoid conditions of trapped air or partially-filled pipe. This can occur when there is low flow and open discharge near to the meter.

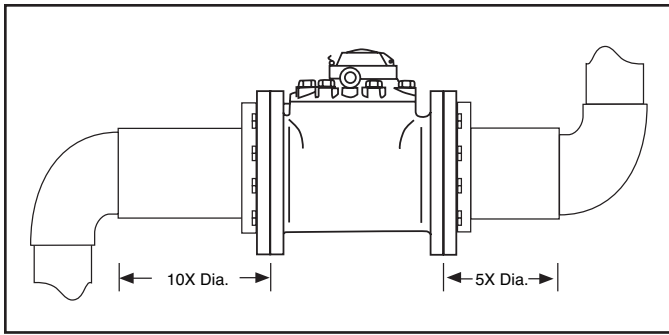

Flanges. The WJ meter is compatible with any standard 150 lb. ANSI drilling, flat or raised face. Take care that gaskets (included) do not protrude into the meter due to misalignment. Adhering the gasket to the meter flange with gasket adhesive is a good practice that will aid installation.

Position. WJ-Series are all-position meters, and can be installed horizontally or vertically. Horizontal with register facing up is recommended when possible.

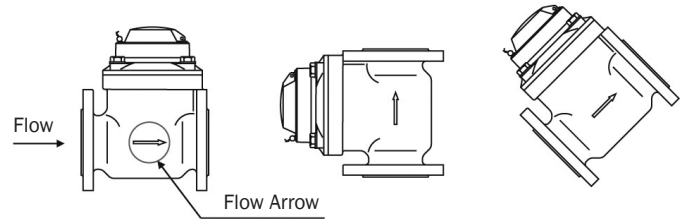

DIMENSIONS

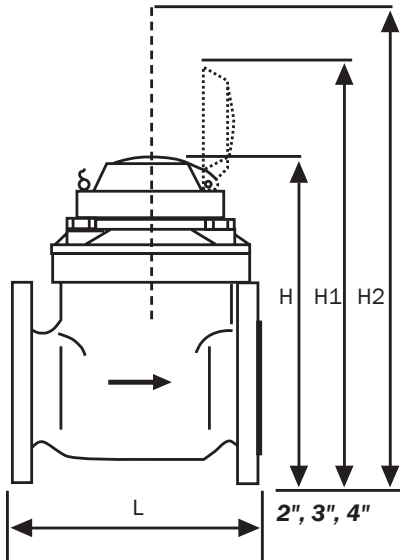

	2"	3"	4"
L	9.625"	8.86"	9.84"
H	10.08"	10.87"	11.26"
H1	12.91"	13.70"	14.09"
H2	15.75"	15.75"	15.75"
Wt.	31 lbs.	45 lbs.	47 lbs.

H1 = Lid clearance for reading display

H2 = Head clearance for replacing turbine insert

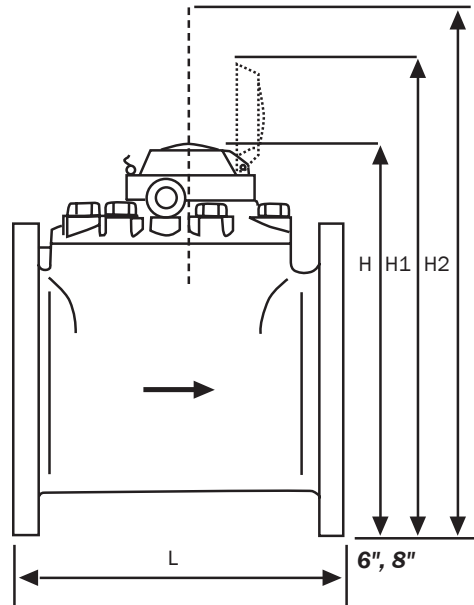

	6"	8"
L	11.81"	13.78"
H	13.60"	14.78"
H1	16.44"	17.62"
H2	19.68"	19.68"
Wt.	95 lbs.	131 lbs.

H1 = Lid clearance for reading display

H2 = Head clearance for replacing turbine insert



CAUTION: Before breaking the tamper-evident seal on your meter, be sure that you are in compliance with any regulatory requirements (if applicable).

Register Removal. Clip and remove the copper security wire from the flange bolt (see Caution note). Remove the security pin that holds the lid in place, twist the lid and lift it off. Lift the register free from the meter, noting orientation.

Field-Changing Pulse Rates. For the contacting head option, WJ meters use a meter-mounted reed switch to provide a two-wire dry contact. To add a reed switch or change your pulse rate in the field, remove the register as described above. Then:

1. Choose desired pulse rate and switch position.

Setting Your Pulse Rate			
Size (inches)	Size (mm)	Pulse Rate	Reed Switch Position
2"	50	10	x1
		100	x10
3"	80	100	x10
		1,000	x100
4"	100	100	x10
		1,000	x100
6"	150	100	x10
		1,000	x100
8"	200	1,000	x100
		10,000	x1000

2. Insert the gray reed switch sensor into the side of the register nearest the dial with desired pulse rate.

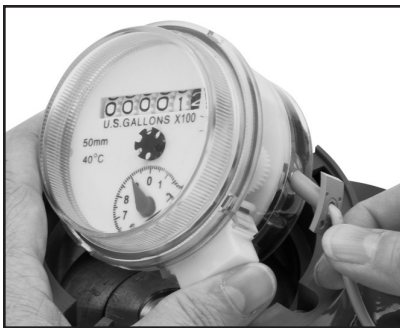

4. Replace the register with the solid plastic tab seated in the retaining ring to prevent rotation.
5. Thread the reed switch cable through the channel in the retaining ring to the outside of the meter.
6. Reverse the procedure to close up the meter.

Recalibration. For meters used for revenue-billing purposes, some states require periodic calibration checking. This type of turbine meter is most commonly checked every four years. Testing may be done by a local mobile meter service or in a private or municipal meter shop. Changes in calibration should be made at an authorized meter shop.

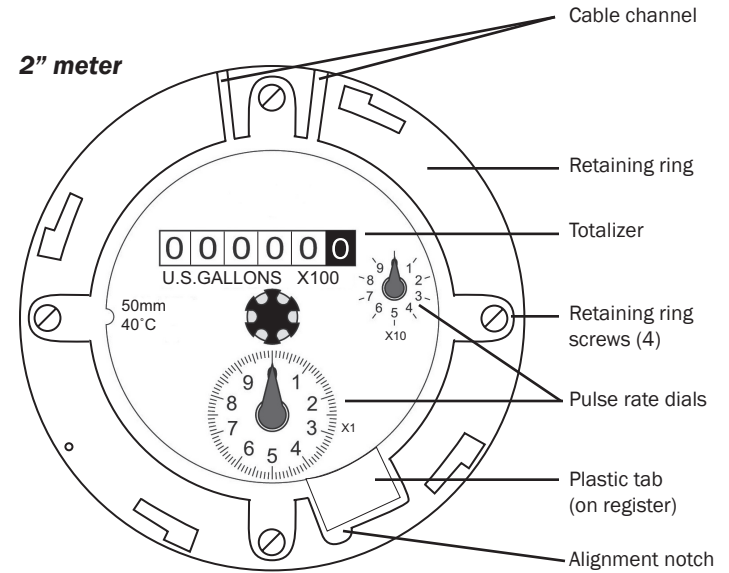

Turbine Insert Replacement. The entire turbine insert comes out as a unit without removing the meter from the pipe. Carefully noting position and retaining parts for reassembly...

1. Remove the lid and register as described.
2. After relieving pressure inside the meter, remove the four flange hex-screws and washers.
3. Lift the flange and insert out in one piece, rocking gently to break the seal.
4. Remove the four retaining ring screws, and lift the retaining ring and flange off the turbine insert.
5. Remove and replace the large O-ring around the top opening of the meter body.
6. Reassemble the retaining ring and flange on top of the new insert. Be sure the alignment notch in the retaining ring is directly above the screw in the insert's top plate.
7. Replace the entire mechanism in the meter body with the drilled screw head in the same corner as the security pin.
8. Replace the lid with a twist of the wrist, insert the security pin in the tiny hole in the retaining ring, and thread the security wire through the screw head and the security pin. Affix lead seal and crimp.

