

EM101

Seametrics

LOW FLOW MAGNETIC FLOWMETER INSTRUCTIONS



EM101 LOW FLOW MAGNETIC FLOWMETER INSTRUCTIONS

ISO 9001:2011
CERTIFIED

TABLE OF CONTENTS

General Information

Features, Specifications, Flow Range Page 1

Installation and Operation

Mounting, Connections, Grounding, Display, Outputs, Mounting Diagrams Page 2

Connections and Grounding

Flow Meter, Display Board, Ideal Grounding with Metallic Piping, Standard Grounding Page 3

FT520 Batch Control Page 4

Settings

Set-Up Page 5

Troubleshooting

Problems, Probable Causes, Things to Try Back

TABLES, DIAGRAMS & CHARTS

Features Page 1

Specifications Page 1

Flow Range Page 1

Mounting Diagrams Page 2

**

Standard Connections and Grounding Diagrams Page 3

FT520 Connection Diagram Page 4

Settings Diagrams Page 5

Troubleshooting Problems, Probable Causes, Things to Try Back

GENERAL INFORMATION

The EM101 is a small electromagnetic low-flow flowmeter with chemically-resistant plastic wetted parts and platinum electrodes suitable for use with a variety of chemicals. Capable of measuring pulsating flows from diaphragm-type metering pumps, it is designed primarily for electrically-conductive chemical injection applications. The 1/4" and 3/8" sizes monitor maximum flows of 1 and 3 gallons per minute (or 4 and 11 L/min), respectively. Barb or NPT fittings are available, and must be designated at

time of order.

The EM101 is 115 Vac, 60 Hz powered and includes a rate and total display as well as a variety of outputs. For continuous transmission of a flow signal, there is a 4-20 mA output, a 0-5 volt signal, and a frequency signal proportional to flow. In addition, there are relay alarm outputs for user-set low and high flow levels.

FEATURES

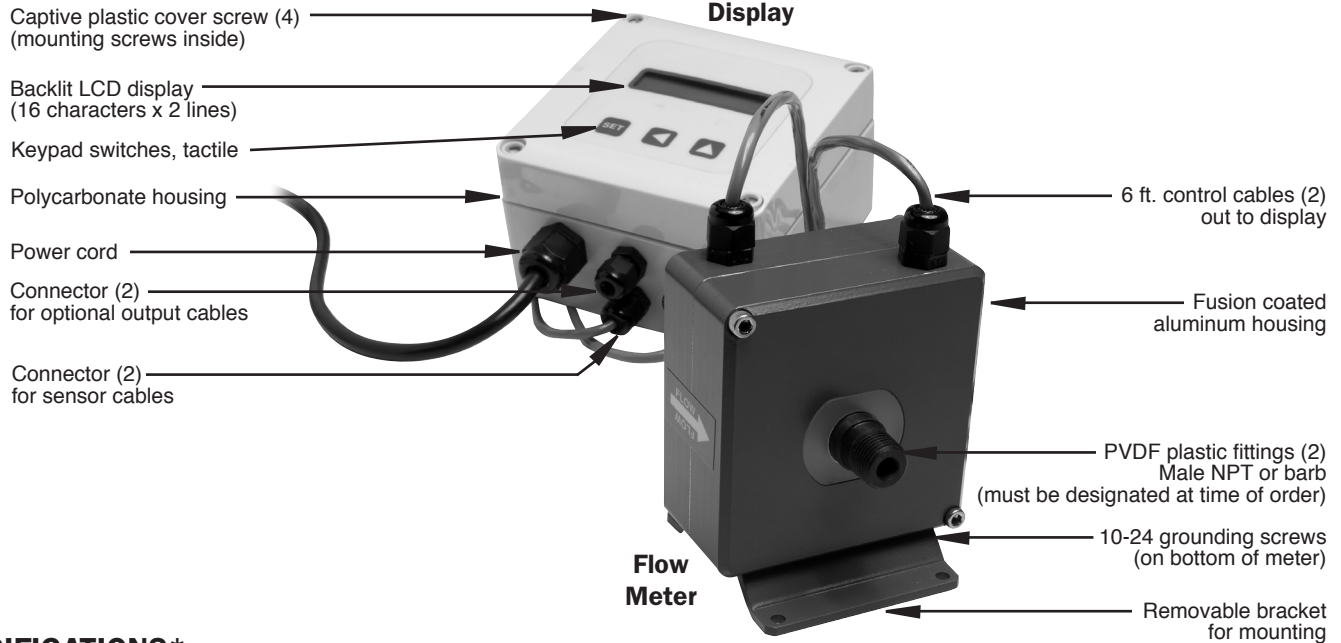

SPECIFICATIONS *

Materials	Meter Housing	Fusion coated aluminum
	Electrodes	Platinum
	O-Ring	Viton™ (EPDM optional)
	Display Housing	Polycarbonate
Rate Display Units		Gal/Minute, Liters/Second, Gal/Hour
Total Display Units		Gallons, Liters
Power		115 Vac, 60 Hz
Accuracy		+/-1% of reading, plus .005 gpm (0.02 lpm)
Max Fluid Temperature		185° F (85° C)
Maximum Pressure		150 psi (@ 75° F)
Minimum Conductivity		>20 microSiemens/cm
Outputs		<ul style="list-style-type: none"> • 4-20 mA, 0-5 Volts, both isolated • Frequency to 9999 pulses per gallon, isolated (10 mA, 30 Vdc) • High alarm, low alarm relay, isolated (100 mA, 110 Vac/Vdc)

*Specifications subject to change • Please consult our website for current data (www.seametrics.com).

FLOW RANGE

SIZE	LOW FLOW CUTOFF			MINIMUM FLOW for spec accuracy			MAXIMUM FLOW		
	L/MIN	GAL/MIN	GAL/HR	L/MIN	GAL/MIN	GAL/HR	L/MIN	GAL/MIN	GAL/HR
-025	.04	.01	.60	.26	.07	4.2	3.8	1	60
-038	.11	.03	1.80	.76	0.2	12	11	3	180

INSTALLATION and OPERATION

INSTALLATION

Mounting. Mount the display housing to a secure surface with screws or bolts. Remove the front cover to gain access to the mounting holes, directly under the front cover screws. Attach the flow meter to a secure surface using the foot bracket. Alternatively, the unit can be supported by the piping and the foot bracket removed. See mounting diagrams below.



CAUTION: Although this meter has an empty pipe detection function, under certain conditions of empty or partially-full pipe the meter may read a flow when there is none. If this is a hazardous condition, mount the meter in such a way as to ensure the meter will always be full of liquid.

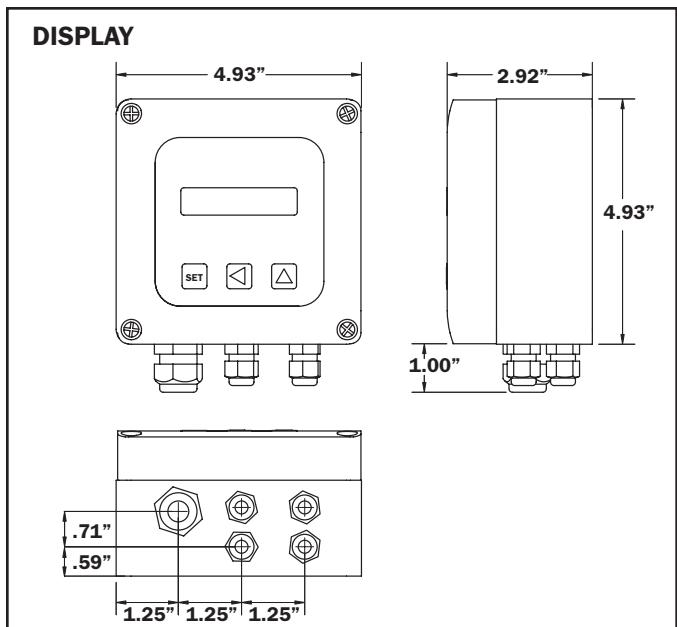
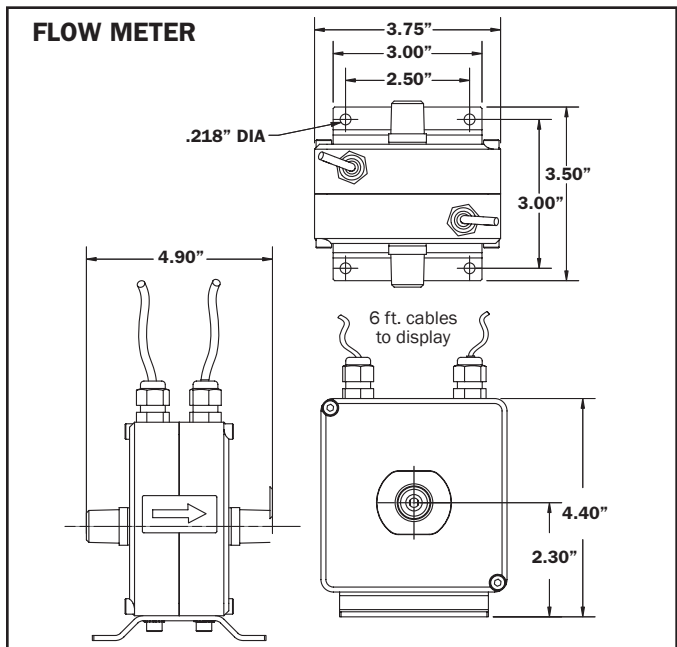

CONNECTIONS

The meter ships with the coil activation and signal leads already connected to the display housing. To connect optional output signal or alarm relay leads, remove the front cover. See the Connections diagram, page 3. Power connection uses a standard power cord. If conduit connection is required, remove the cord and strain relief and use the strain relief hole for a conduit connector.

Grounding. For proper operation, one or both of the ground lugs must be well connected to a good quality earth ground. (The ground lugs also retain the foot bracket). See the Grounding diagrams, page 3. The meter comes with a 12 foot ground wire attached.

OPERATION

Display. The flow rate is displayed in the time and volume units that have been selected in Set-Up (page 5) (liters/min, for example). The cumulative total flow is displayed in the chosen units, up to eight digits. When the total reaches its maximum, the display resets to zero and begins again.

Outputs. The **analog output** varies continuously with the flow. If the output is too "jumpy" (changes too frequently), it can be damped in one of two ways: 1) increase the averaging time (under the Fast Analog Output setting); **or** 2) select "Disabled" (the default condition) under Fast Analog Output and increase the amount of damping using the Low Pass Filter setting.

The **pulse output** will produce a 50% duty cycle pulse at the volume intervals for which it is set - one pulse per liter, for example. Note: Since each pulse consists of equal times on and off, if the interval between pulses is large, the pulse may remain in the "on" condition for several seconds.

The **relay alarm output** will only energize if the flow goes above (high) or below (low) the flow alarm setting. The alarm relay will remain energized until the flow exceeds the setpoint by .25% (hysteresis).

CONNECTIONS

FT520 - BATCH CONTROL

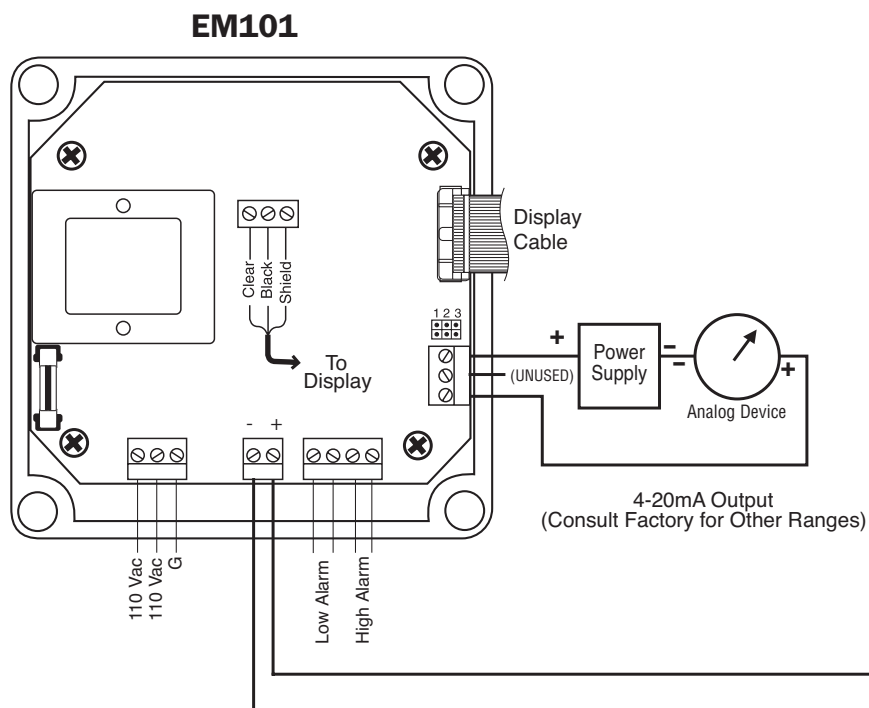
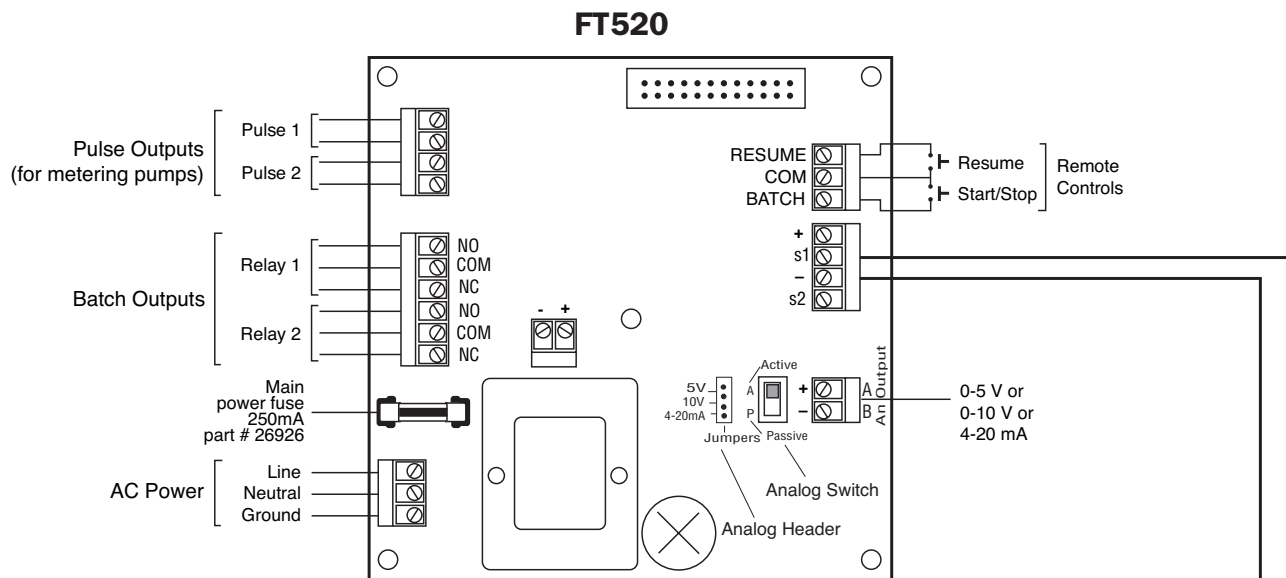

SETTINGS

SET-UP. Use the instructions below to set up your control. Use the **SET** key to move from one operation to the next, and use the **▲** and **◀** keys as described to change settings within operations.

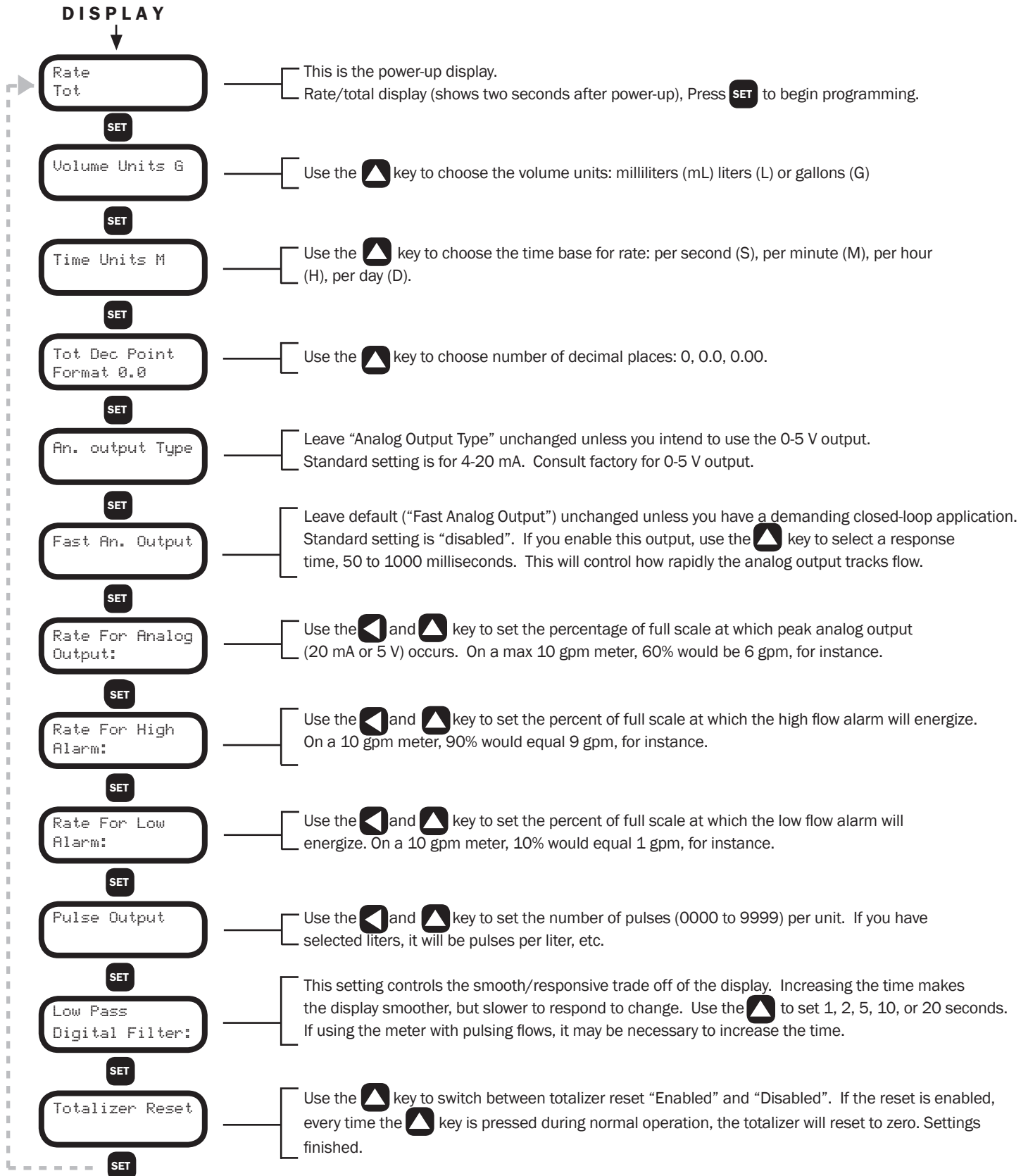

TROUBLESHOOTING

Problem	Probable Causes	Try...
No Display	No power Blown fuse Loose ribbon cable	Check for 110 Vac Test fuse, replace if bad Check ribbon cable connections
Flow rate always reads "0"	Reversed flow direction Missing ground wire Empty pipe Flow rate below minimum Loose wiring or incorrect wiring Fluid conductivity <20 microSiemens/cm	Reverse flow connections Install ground wire Install meter in vertical position Use next smaller flow meter Check connections on display board Select another flow meter
Flow rate incorrect	Missing or incorrect ground wire Fluid conductivity <20 microSiemens/cm Empty pipe	Check for proper grounding Select another flow meter Install meter in vertical position



Seametrics Incorporated • 19026 72nd Avenue South • Kent, Washington 98032 • USA
(P) 253.872.0284 • (F) 253.872.0285 • 1.800.975.8153 • www.seametrics.com