

S-SERIES

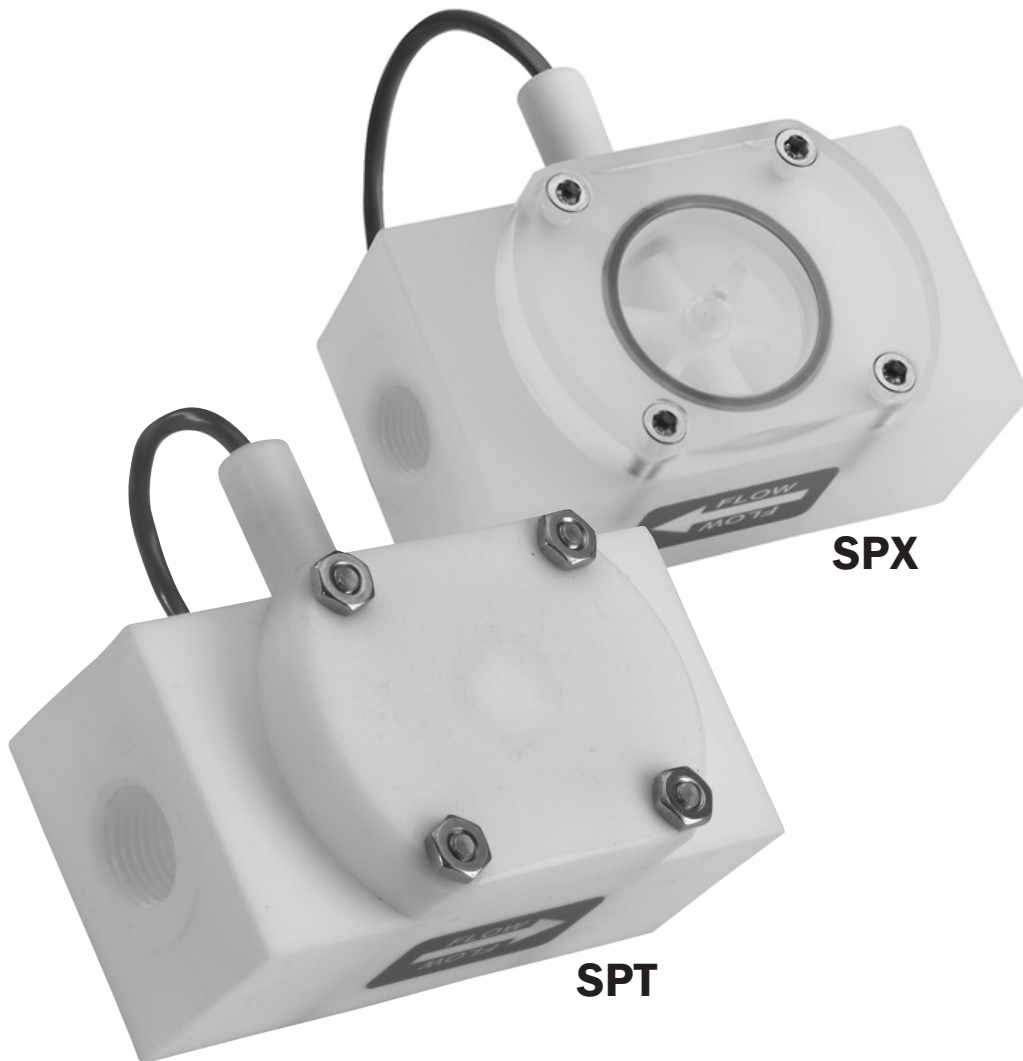

LOW FLOW METER INSTRUCTIONS



S-SERIES LOW FLOW METER INSTRUCTIONS

GENERAL INFORMATION, FEATURES, SPECIFICATIONS

These versatile impeller flowmeters are available in 3/8", 1/2", 3/4", and 1" nominal pipe sizes with female NPT threads (SAE optional). They employ jewel bearings to allow for very low minimum flow rates and superior life.

With a body material of polypropylene, the **SPX** is an economical choice for metering water or low corrosion fluids. The lens cover is available in a choice of materials: acrylic for visual flow indication of low-corrosive fluids; polypropylene when more corrosion resistance is needed. The standard rotor assembly is Kynar with tungsten carbide shaft (ceramic shaft optional). The O-ring is EPDM.

The **SPT** offers greater chemical resistance with a Teflon body and cover, Teflon-coated Viton O-ring, and standard Kynar/ceramic rotor assembly (carbide shaft optional).

The pulse output of these meters is compatible with many different types of controls, including a full range of Seametrics rate displays and controls. The Seametrics FT420 provides flow rate and total flow indication, with 4-20 mA output capability. The FT415 is a battery-operated rate & total display. For metering pump pacing or interfacing with lowspeed counters, the PD10 pulse divider is recommended. The AO55 may be used for blind 4-20mA transmission.

FEATURES

- Thread-in Sensor, Field Replaceable, 6-24 Vdc pulse
- 18' Sensor Cable
- Removable Lens Assembly
- Standard Acrylic Top (SPX)
- Hex Screws
- Female NPT Ports (SAE optional)
- (Internal) Jewel bearings
- Kynar/Carbide or Kynar/Ceramic Rotor Assembly
- EPDM (SPX) or Teflon-coated Viton (SPT) O-ring

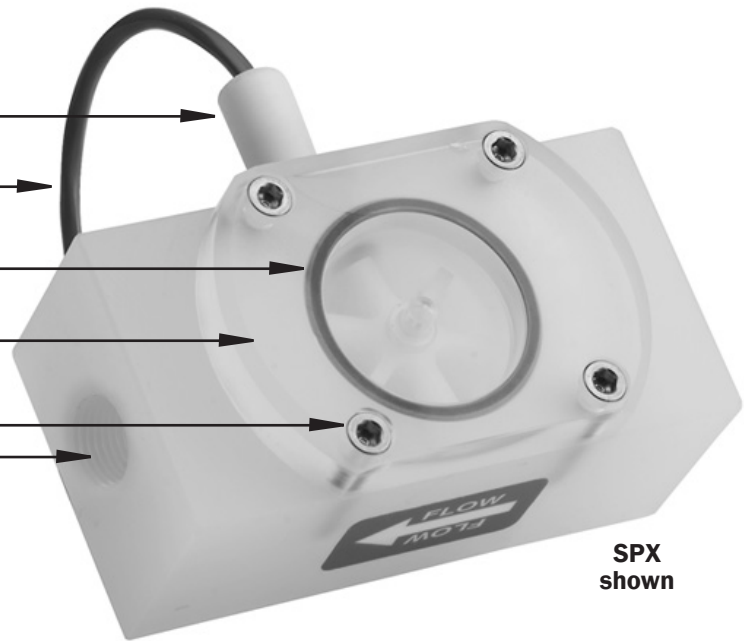

| SPECIFICATIONS* | SPX | SPT |
|----------------------------|--|--|
| Connection Ports | 3/8", 1/2", 3/4", 1", Female NPT thread (SAE optional) | 3/8", 1/2", 3/4", 1", Female NPT thread (SAE optional) |
| Sensor Cable | 18 feet standard (Maximum cable run 2000 ft.) | 18 feet standard (Maximum cable run 2000 ft.) |
| Materials | | |
| Body | Polypropylene | TFE Teflon |
| Rotor | PVDF (Kynar) | PVDF (Kynar) |
| Shaft | Nickel tungsten carbide (zirconia ceramic optional) | Zirconia ceramic (silicon carbide optional) |
| O-Ring | EPDM (Kalrez or Teflon-coated Viton optional) | Teflon-coated Viton (EPDM or Kalrez optional) |
| Bearings | Ruby ring and ball | Ruby ring and ball |
| Cover | Acrylic (Polypro optional) | TFE Teflon |
| Maximum Temperature | 160° F (70° C) | 160° F (70° C) |
| Maximum Pressure | 150 PSI (10 bar) | 150 PSI (10 bar) |
| Accuracy | ±1% of full scale | ±1% of full scale |
| Power | 5-24 Vdc, 2 mA min | 5-24 Vdc, 2 mA min |
| Outputs | Current sinking pulse, 6-24 Vdc | Current sinking pulse, 6-24 Vdc |
| Regulatory | CE Mark (Standard Power Only) | CE Mark (Standard Power Only) |

*Specifications subject to change • Please consult our website for current data (www.seametrics.com).

INSTALLATION, CONNECTIONS

INSTALLATION

Piping Requirements. Standard fittings are female NPT. If the piping connected to the meter is metallic, care should be taken not to overtighten. Straight pipe of at least five diameters upstream of the meter is recommended. Vertical, horizontal, or inverted (lens down) installations are all acceptable.

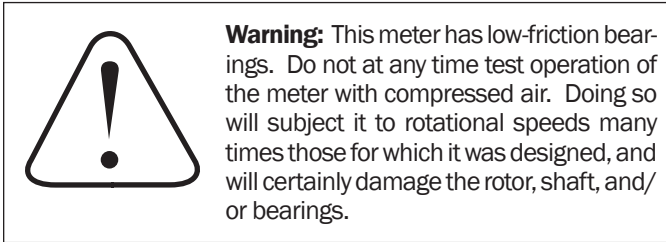

K-Factor. The meter is factory calibrated. The K-factor is found on the label on the meter body and must be input into the control/display for accurate reading.



CONNECTIONS

Connecting to Non-Seametrics Control Devices. It is often desirable to connect an SPX/SPT flow sensor to a PLC or industrial computer board, and the sensors are well suited for this. Typically it can be connected directly, or with a single resistor added. The pickup sensors are current sinking (NPN) GMR devices that require 5-24 Volts DC and 2 mA current. They can connect directly to a PLC or computer board (See **Fig. 1**) if:

1. The sensor power supply on the PLC is 5 - 24 Vdc (24 Vdc is typical).
2. The sensor power supply can provide at least 2 mA (100 mA is typical).
3. The sensor input on the PLC can accept a current sinking device.
4. The PLC frequency response > flow meter output frequency.

If the PLC input only accepts current sourcing devices, a pull-

up resistor must be added (See **Fig. 2**). Typically, on a 24 Vdc input a 2.2 K Ohm resistor will be effective.

Figure 2
Input Designed for Current Sourcing (PNP) Devices

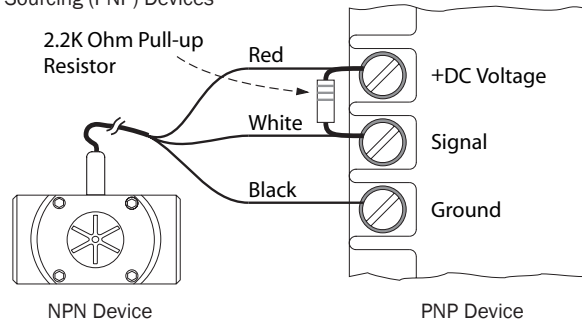
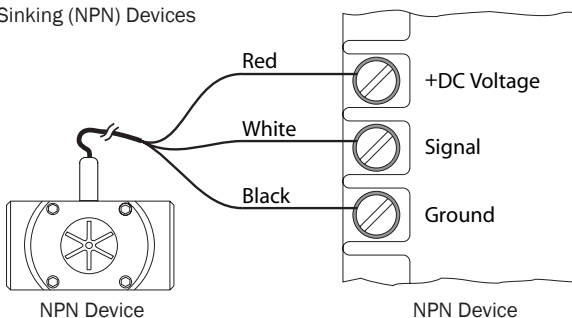

Figure 1
Input Designed for Current Sinking (NPN) Devices



Since the three-wire pickup sensors are solid state, they do not exhibit switch bounce and can be used at relatively high frequencies.

If the PLC is equipped with a 4-20 mA analog input module, it is necessary to order the S- Series flow sensor with some form of 4-20 mA transmitter. Two options are the A055 blind transmitter and the FT420 indicating transmitter. Follow the connection diagrams for these products to connect to the analog input.

REPAIR

Rotor Replacement. There is only one moving part to this meter. The bearings are made of ruby, which rarely wears out or needs replacement unless they have been physically damaged by severe shock. The shaft is integrally molded into the rotor, and shaft and rotor are replaced as one part. (You may wish to replace the bearings, using the bearing removal tool, while the meter is disassembled for rotor replacement). To replace the rotor, disconnect the meter and remove the four screws that hold the cover in place. Lift the cover and remove the rotor (see parts diagram below).

When putting in the new rotor, be sure that the ends of the shaft are in both bearings before tightening the cover. The rotor can be easily dropped into the bottom bearing. Starting the shaft into the upper bearing requires a bit of care. It is easier if the rotor is spinning, which can be done by lightly blowing into a port. When the upper bearing plate drops into place, hold it down and check for free spinning (by blowing lightly) before replacing the cover. Check that the O-ring is in its seat on the bearing plate before replacing the cover. Replace the cover, insert the four cap screws and tighten.

replacement unless it is electrically damaged. If replacement is necessary, unthread the sensor by hand. Thread the replacement sensor in and tighten by hand.

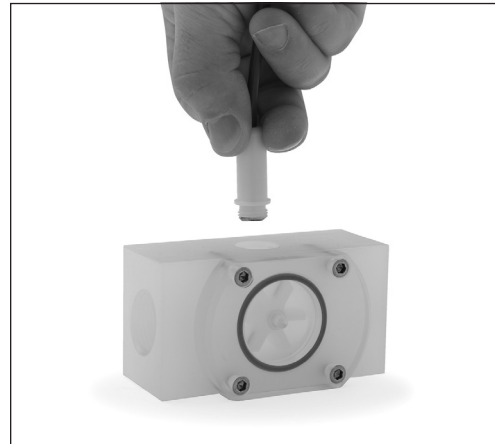

Reconnect the sensor according to the diagram below.

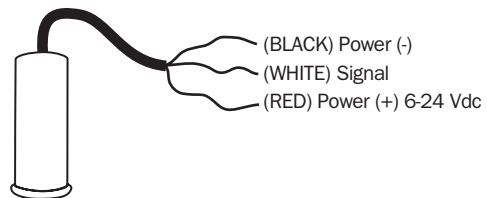

Sensor Replacement. The sensor ordinarily does not need

SPX/SPT PARTS LISTING

| | | SPX | | SPT | |
|--|---|-------------|------------|-------------|------------|
| 1 Body | -038 | 16471 | | 25104 | |
| | -050 | 16472 | | 25103 | |
| | -075 | 16473 | | 25102 | |
| | -100 | 16474 | | 25101 | |
| | | | | | |
| 2 Flow Direction Label | | 19036 | | 19036 | |
| 3 Bearing Assembly (2 required) | | 16772 | | 16772 | |
| | Bearing Removal Tool (not shown) | | 26108 | | 26108 |
| 4 Rotor with Shaft | Kynar/ceramic (2 magnet) | | 11127 | | 11127 |
| | Kynar/carbide (2 magnet) | | 11129 | | 11129 |
| | Kynar/ceramic (6 magnet, high res) | | 11132 | | 11132 |
| | Kynar/cabide (6 magnet, high res) | | 11130 | | 11130 |
| | | | | | |
| 5 O-Ring | EPDM | | 25081 | | |
| | Teflon-coated Viton® | | | | 31403 |
| | | | | | |
| 6 Cover | | Before 5/05 | After 5/05 | Before 5/05 | After 5/05 |
| | Polypro | 16018 | 31007 | | |
| | Acrylic | 16022 | 31006 | | |
| | TFE Teflon | | | 26174 | 31005 |
| 7 Cover Screws (4 required) | Hexscrew | | 25370 | | |
| | Screw (use with hexnut 07705) | | | | 07685 |
| | Hexnut (use with screw 07685) | | | | 07705 |
| | | | | | |
| 8 Sensor | | | | | |
| | Standard | | 26310 | | 26310 |
| | Micropower | | 29953 | | 29953 |

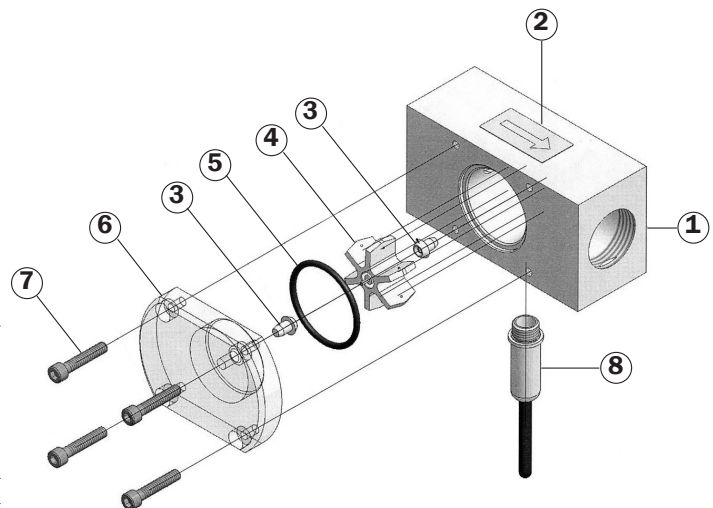

Seametrics Incorporated • 19026 72nd Avenue South • Kent, Washington 98032 • USA

(P) 253.872.0284 • (F) 253.872.0285 • 1.800.975.8153 • www.seametrics.com