

WMX-SERIES

MUNICIPAL/INDUSTRIAL MAGMETER INSTRUCTIONS



WMX104

WMX101

ISO 9001:2000
CERTIFIED

SeaMetrics

The Leader in Flow Meter Value

FEATURES AND SPECIFICATIONS

FEATURES

- Rate and total indicator _____
- Power/Output cable port access _____
- Diecast-aluminum electronics housing _____
- Equalization lug _____
- Welded steel epoxy-coated flow tube _____
- 316SS electrodes _____
- Flanges, ANSI 150 lb. drilling _____
- HDPE liner _____

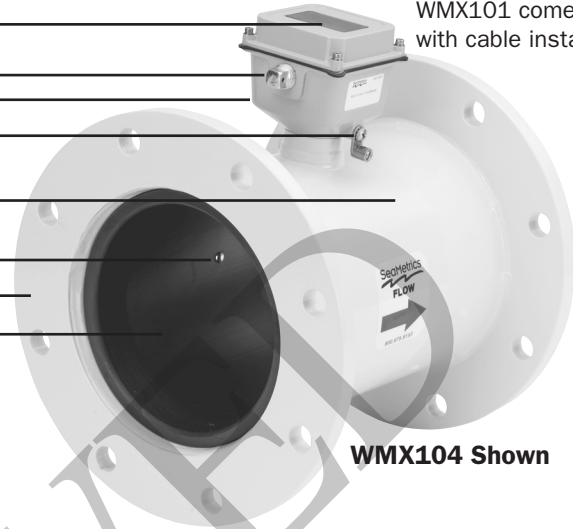

WMX101 comes with cable installed

WMX104 Shown

SPECIFICATIONS

Pipe Sizes	4", 6", 8", 10"	
Flanges	ANSI 150 lb. drilling	
Pressure	150 psi working pressure	
Temperature Range	10° F to 130° F	
Accuracy	+/-1% of reading from 10% to 100% of full scale +/-2% of reading from cut off to 10% of full scale	
Materials	Body	Welded steel, epoxy powder coated
	Liner	HDPE
	Electronics Housing	Diecast aluminum
	Electrodes	316 stainless steel
Display	Rate	Total
	Digits	6
	Units*	8
		Gallons/Minute
		Million Gallons/Day
		Liters/Second
		Liters/Second
		Cubic Feet/Minute
		Gallons x 1000
		Gallons x 1000
		Cubic Meters
		Megaliters
		Cubic Feet
Power	WMX101: 7-26 Vdc at 30 mA max, with battery backup for continuous operation during power failures (See WARNING on wiring diagrams)	
	WMX104: 2 Lithium 3.6V "D" batteries, replaceable, 3 year life	
Output Signal	WMX101: Current sinking pulse, opto-isolated, 24 Vdc at 10 mA max	
	WMX104: Pulse output available only with addition of post-factory output cable	
Empty Pipe Detection	Hardware/software, conductivity-based	
Environmental	NEMA 4X	

FLOW RANGE

	4"		6"		8"		10"	
	Gal/Min	Liter/Sec	Gal/Min	Liter/Sec	Gal/Min	Liter/Sec	Gal/Min	Liter/Sec
Minimum	12	.75	32	2	60	3.8	95	6
Maximum	500	31.5	1,200	75.7	2,200	138.8	3,500	220.8

GENERAL INFORMATION, INSTALLATION, GROUNDING

The **WMX-Series** are flanged electromagnetic flowmeters for use in 4" to 10" pipe in municipal or industrial water and wastewater applications where propeller meters have typically been used in the past. Because the WMX has no moving parts and electrodes designed to discourage fouling, this magmeter performs well and requires much less frequent maintenance in applications where debris or sand would impede propeller meters. There is no rotor to stop turning or bearings to wear out. Minimal straight pipe requirements allow WMX-Series meters to be used in piping configurations where there is little space between the meter and an elbow.

Rate and total indication is standard on both models. Flow measurement units are customer-selected and factory-set and can only be changed in the field by an authorized SeaMetrics dealer.

The **WMX101** is externally powered with 7-26 Vdc at 30 mA max (see WARNING on Wiring Diagrams). Two Lithium 3.6V "D" batteries provide backup during power failures, allowing the meter to seamlessly continue recording flow rate and total for the duration of the outage.

The 20-foot cable also provides pulse output for use with a variety of SeaMetrics and other displays and controls for remote reading, data logging, pulse-to-analog conversion, and telemetry applications. Pulse rate is customer-selected and factory-set and can only be changed in the field by an authorized SeaMetrics dealer. Default is high frequency for use with 4-20 mA signal conversion devices.

The **WMX104** is a battery-operated unit for use when no additional input or output is required. The Lithium 3.6V "D" batteries are replaceable with an approximate 3-year life under continuous use, depending on the duty cycle. An optional cable can be installed post-factory if power or pulse output is needed for changing applications.

INSTALLATION



Caution: These flow sensors are not recommended where installation fault may expose the flow sensor to boiler pressure and temperature. Maximum recommended temperature is 130° F.

Positioning the Meter. These meters can be installed horizontally, vertically, and in any radial position.

Straight Pipe Recommendations. As with most flow meters, the WMX requires some straight pipe before and/or after the meter for best accuracy. However, the ability of electromagnetic meters to average the flow across the entire pipe allows for shorter straight pipe recommendations than most mechanical meters (see page 3).

Full Pipe Recommendations. All magmeters require a method for determining that the pipe is empty, to prevent false reading. This meter is designed to go to zero reading

if one or more electrodes is exposed. For highest accuracy, install the meter so that the pipe will be full when there is flow. If air bubbles may be present in the pipe or sludge accumulation is an issue, rotate the meter by one flange hole to position the control housing at a 45° angle. See Full Pipe diagrams on page 4.

Fittings. The WMX flanges have standard ANSI 150 lb. drilling and mate with any other ANSI 150 lb. flange.

Calibration. The WMX is factory-calibrated and will not require any form of field calibration.

EQUALIZATION AND GROUNDING

Metal Pipe Installations. To equalize the electrical potential of the fluid, the WMX101 or 104, and the surrounding pipe, secure the flange plates (factory-installed on the equalization lug) to both pipe flanges at one of the bolt holes, as shown below. Be sure the lockwasher fits between the pipe flange and the flange plate.

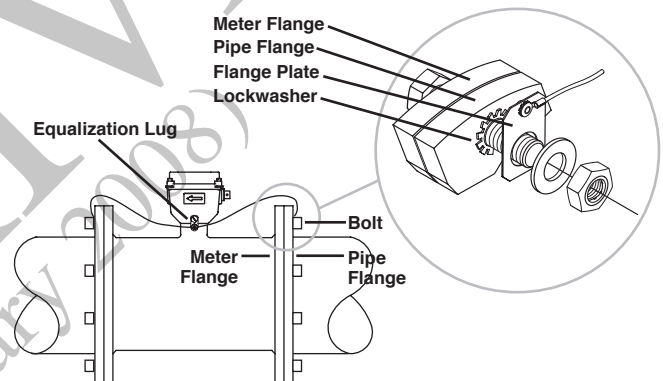

Equalization Diagram

Run wire from equalization lug to both pipe flanges; secure flange plates under bolt head as shown.



WARNING: ELECTRICAL SHOCK HAZARD When the meter is externally AC powered (WMX101 or adapted 104), the piping system must be grounded to meet national and local electrical safety codes. Failure to do so can result in electrocution.

Plastic Pipe Installations. When the WMX is installed in a plastic piping system, it is not necessary to use the equalization straps, but very important to ground the meter to avoid electrical shock hazard and electrostatic interference with meter function.

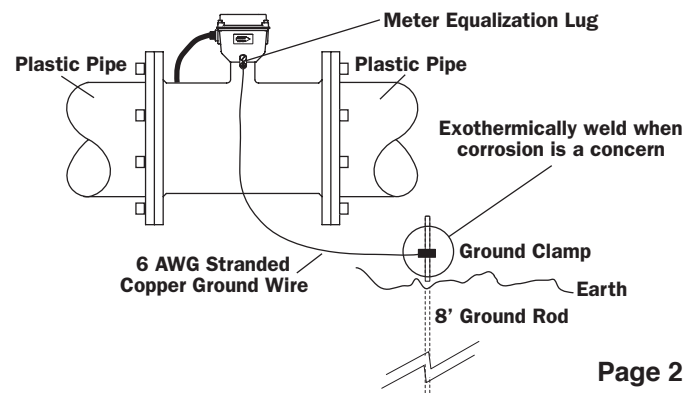

STRAIGHT PIPE RECOMMENDATIONS

(X = diameter)

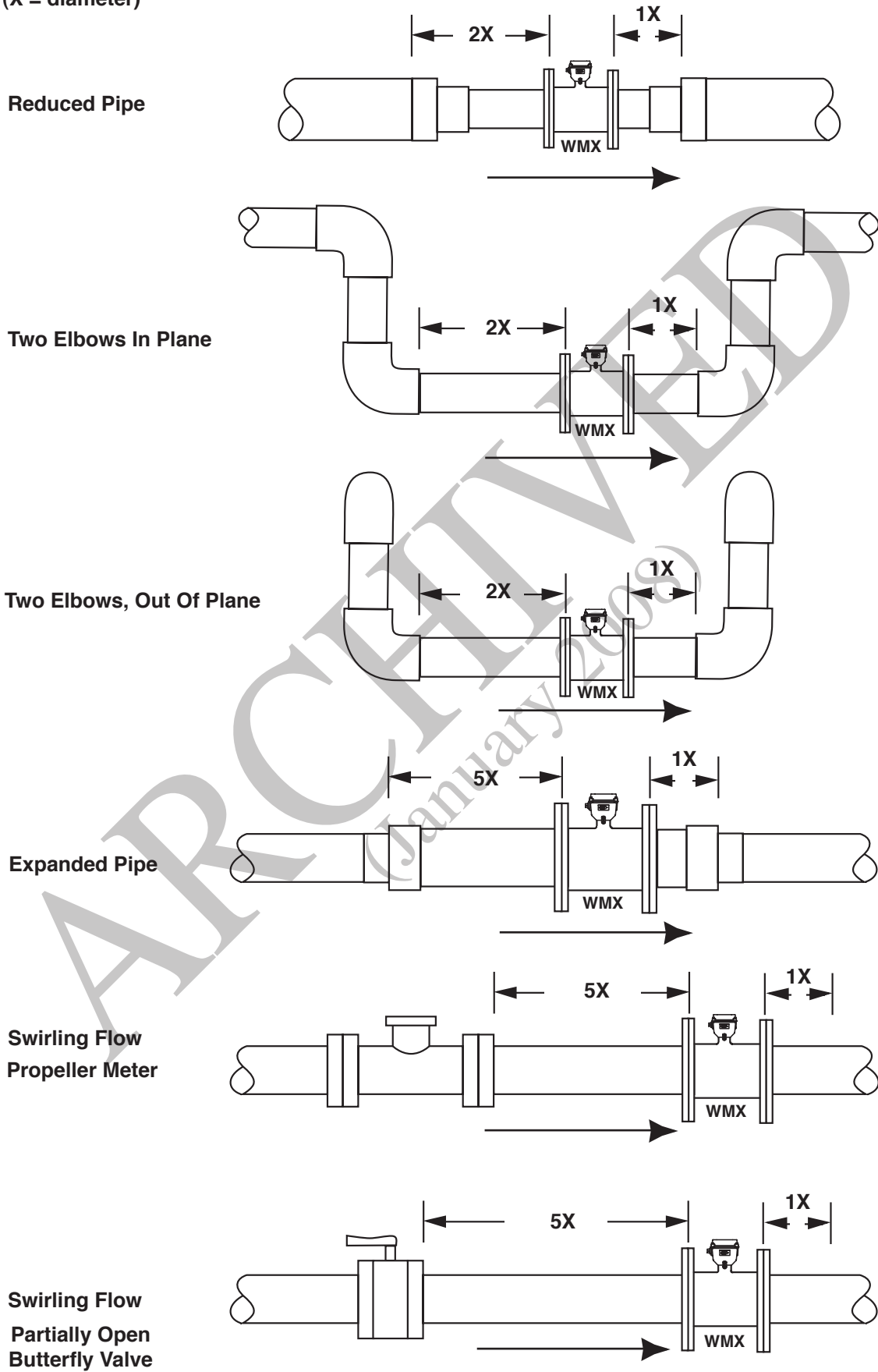

FULL PIPE RECOMMENDATIONS

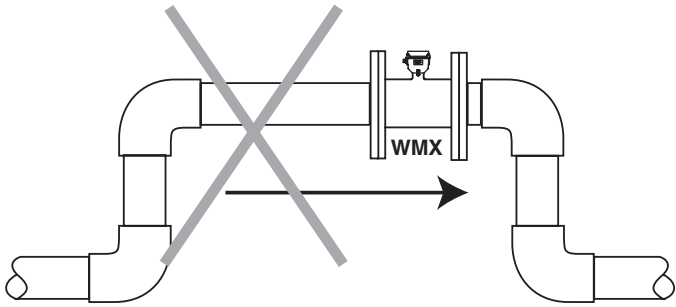

Possible Problem:
Allows air pockets to form at sensor

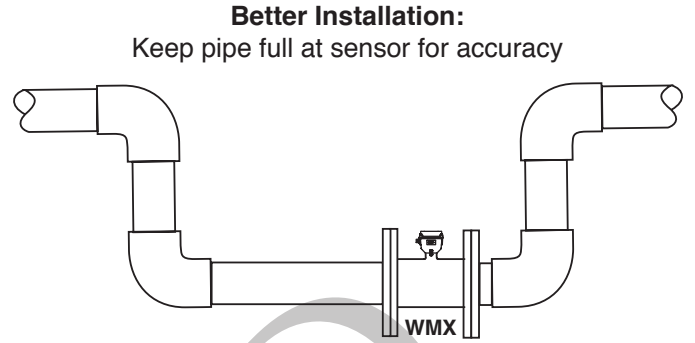

Better Installation:
Keep pipe full at sensor for accuracy

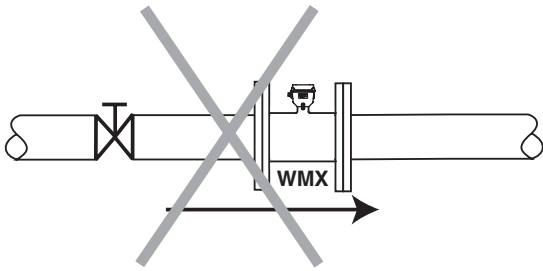

Possible Problem:
Post-valve cavitation can create air pocket

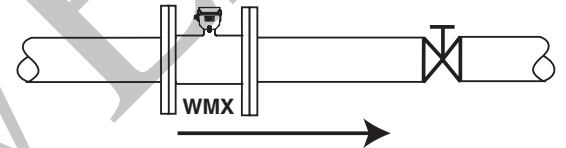

Better Installation:
Keeps pipe full at sensor for accuracy

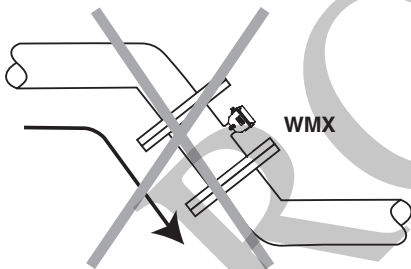

Possible Problem:
Air can be trapped

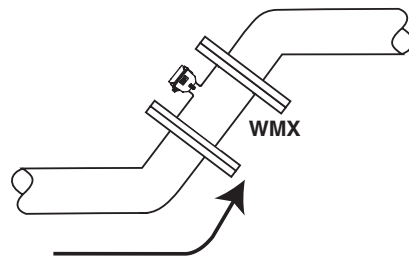

Better Installation:
Allows air to bleed off

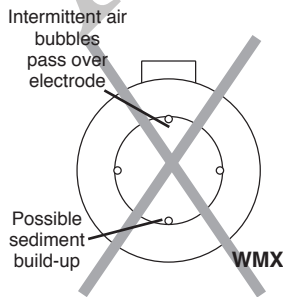

Possible Problem:
Air bubbles and sediment on the electrodes can affect accuracy.

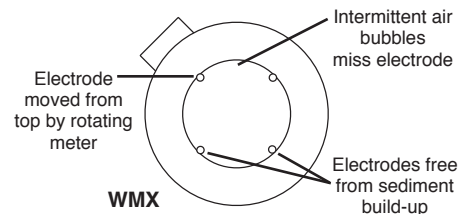

Better Installation:
Improved accuracy results from unimpeded electrodes.

INPUTS AND OUTPUTS

WMX101

External Power (WMX101). The WMX101 operates on 7-26 Vdc at 30 mA max external power (see WARNING in wiring diagrams). The display reads “P” when external power is in use (see illustration).

The Lithium battery pack installed in the WMX101 serves as backup in the event of a power failure, when it will keep the meter operating without interruption for the duration of the outage. When battery power is in use, the WMX101 display continues to read out the rate and total, but the “P” indicating external power is extinguished. When power resumes, the WMX101 will seamlessly return to normal power mode, and the “P” will again display.

When used for occasional emergency backup, battery life is approximately ten years.

Pulse Output (WMX101). The WMX101 cable also provides pulse output that can be used for remote reading, 4-20 mA signal conversion, datalogging, and telemetry applications. See page 6 for connection diagrams to SeaMetrics controls and displays.

Pulse rates are selected by the customer at time of order, factory-set, and can only be changed in the field by an authorized SeaMetrics dealer. Three pulse rates are possible: One pulse per ten gallons (or liters), one pulse per thousand gallons (or liters), or High Frequency (required for use with 4-20 mA converters; see below):

High Frequency Output		
Meter Size	Pulses per Gallon	Pulses per Liter
4"	16.362	4.323
6"	6.307	1.666
8"	3.344	0.883
10"	2.150	0.568

WMX104

Battery Power (WMX104). The WMX104 is powered by a non-rechargeable battery pack with an average lifespan of three years under typical (full-time) use. Actual lifespan will vary from application to application, depending on the duty cycle.

“Low Batt” will display when there are approximately three days of use left in the batteries (see illustration). Replacement instructions come with the custom battery pack available from your dealer or SeaMetrics.

Pulse Output (WMX104). Pulse output capabilities are built in to the WMX104, but cannot be utilized without the addition of an optional output cable. A WMX104 can be retrofitted with this cable in the field.

OPERATION



Caution: There are no user-adjustable connections or settings inside the display housing. Use caution when opening the housing for a battery change, to avoid damage to internal components.

Display Reading. The WMX display has two lines, the bottom line for flow rate and the top line for accumulated total. Measurement units are pre-ordered and factory-set and can be changed in the field only by an authorized individual.

Refer to the diagrams below to read your display.



External Power Indicator
(WMX101 Only)



No Power



Battery Power
(WMX104 Standard Operation)
(WMX101 Backup Operation)



Empty Pipe

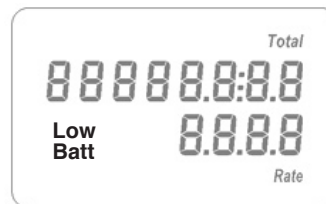

Low Battery Indicator
(3 days remaining)



Meter Installed Backwards

CONNECTIONS DIAGRAMS (WMX101)

The **WMX101** requires a power source of 7 to 26 Vdc at 30 mA max (see **WARNING**). The WMX101 power cable also serves as a pulse output if needed for remote reading, data logging, signal conversion, or telemetry.

WMX101 Cable Color Codes

Orange (+) and Blue (-): Serial Output (Do Not Use)

Green (+) and White (-): Pulse Output, 30 Vdc max, 10 mA max

Red (+) and Black (-): External Power, 7-26 Vdc at 30 mA max

Drain: Connect to earth ground (see **WARNING**)

A055/WMX101

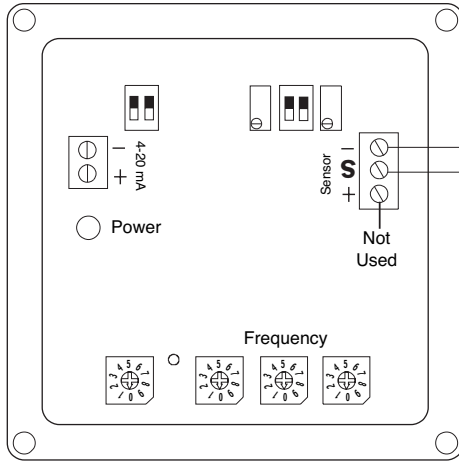

A055W Pulse-to-Analog Converter

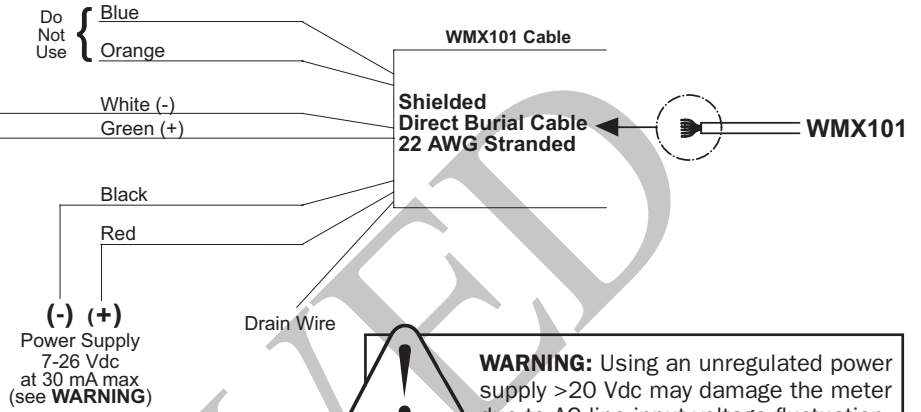

WARNING: Using an unregulated power supply >20 Vdc may damage the meter due to AC line input voltage fluctuation.

FT420/WMX101

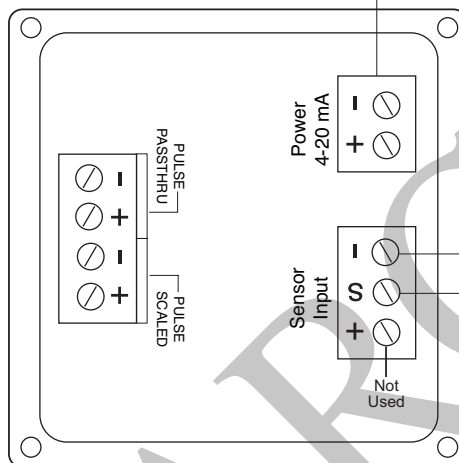

FT420W Remote Rate/Total Display

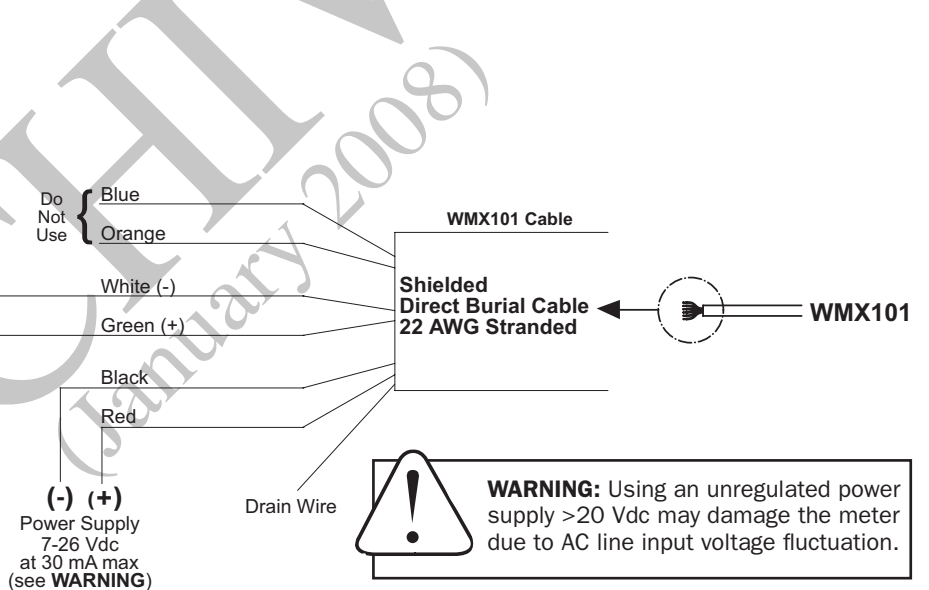

WARNING: Using an unregulated power supply >20 Vdc may damage the meter due to AC line input voltage fluctuation.

DL75/WMX101

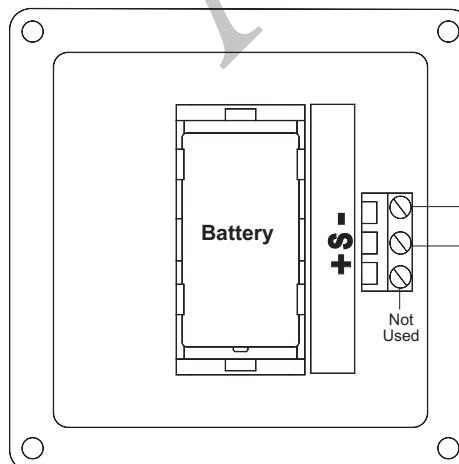

DL75W Data Logger

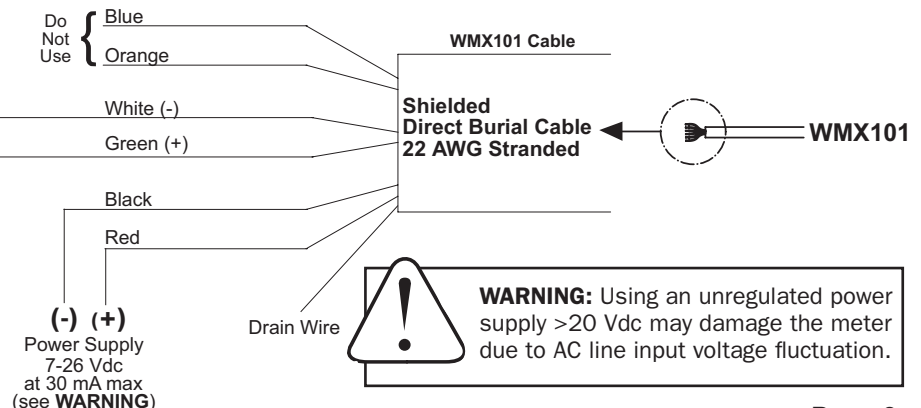

WARNING: Using an unregulated power supply >20 Vdc may damage the meter due to AC line input voltage fluctuation.

TROUBLESHOOTING

Problem	Probable Cause	Try...
Blank Display	Dead battery (WMX104)	Replace battery pack
	No power plus dead battery (WMX101)	Replace battery pack, check power connections
Flow rate steadily reads zero when there is flow	Flow is below cutoff (very low)	Reading will resume when flow increases
	Pipe not full	Reposition meter for full pipe (see page 4)
	Meter is installed backwards (display reads [-])	Note flow direction arrow, reverse meter
	Power connections reversed (WMX101)	Change power connections
Flow rate intermittently drops when there is flow	Fluid conductivity <20mSiemens/cm	Select another flow meter
	Pipe not full	Reposition meter for full pipe (see page 4)
Jumpy reading	Missing or incorrect ground wire	Check for proper ground
Meter reads, but no pulse output (WMX101)	External device needs pull-up resistor	Add pull-up resistor
	Reversed leads (polarity sensitive)	Change output connections
Output pulses missing	Meter not reading	Check display

