

EX100/200 Series

INSERTION MAGNETIC FLOW METER INSTRUCTIONS



EX101
EX201

EX115
EX215

SeaMetrics

The Leader in Flow Meter Value.

EX100/200 SERIES INSERTION MAGNETIC FLOW METER INSTRUCTIONS

TABLE OF CONTENTS

General Information

Specifications, Parts Diagram	Page 1
-------------------------------------	--------

Installation

Piping, Distorted Flows, Immersion, Positioning the Meter	Page 2
Fitting Installation, Meter Installation.....	Page 3
Proper Depth Setting	Page 4
Table 1: Dimension "C", Table 2: Pipe Wall Thickness	Page 5
Straight Pipe Recommendations	Page 6
Full Pipe Recommendations.....	Page 7

Electrical Connections

General Electrical Guidelines, Power, Forward Flow Output, Reverse Flow Output, Grounding Guidelines, Grounding Diagram	Page 8
--	--------

Connections Diagrams

Counter or PLC, A055 4-20 mA Output, FT520 Controller	Page 9
FT420 Display and Proportional Feed, FT420 & 4-20 mA Output, FS30 Flow Switch	Page 10
DL75 Data Logger, FT420/DL75, Dual FT420 Displays (example of bidirectional connections)	Page 11

Operation & Maintenance

Zero Adjustment, Minimum Flow, Presence of Flow Indication, Filtering, Electrode Coating, Calibration ("K-Factor")	Page 12
Flow Rates in Gallons Per Minute, EX Series K-Factor Chart	Page 13

Troubleshooting

Problems, Probable Causes and Things to Try	Back
---	------

TABLES, DIAGRAMS & CHARTS

Parts Diagram	Page 1
Distorted Flows, Positioning the Meter	Page 2
EX101/201, EX115/215, Sensor Removal	Page 3
Proper Depth Setting	Page 4
Table 1: Dimension "C", Table 2: Pipe Wall Thickness	Page 5
Straight Pipe Recommendations	Page 6
Full Pipe Recommendations	Page 7
Grounding Diagram	Page 8
Connection Diagrams: Counter or PLC, A055 4-20 mA Output, FT520 Controller	Page 9
Connection Diagrams: FT420 Display and Proportional Feed, FT420 & 4-20 mA Output, FS30 Flow Switch	Page 10
Connection Diagrams: DL75 Data Logger, FT420/DL75, Dual FT420 Displays (example of bidirectional connections)	Page 11
Zero Adjustment	Page 12
Flow Rates in Gallons Per Minute, EX Series K-Factor Chart	Page 13
Troubleshooting Problems, Probable Causes and Things to Try	Back

GENERAL INFORMATION

The complete lack of moving parts of this insertion flow sensor is the source of its reliability. There is no rotor to stop turning in dirty water and there are no bearings to wear out. Brass, stainless, and PVC models withstand a variety of temperature, pressure, and chemical conditions. Reverse flow output and submersibility are optional.

A rapidly reversing magnetic field is produced in the lower housing, and as the fluid moves through this field a voltage is generated. This tiny voltage is measured and translated into a frequency signal that is proportional to flow rate. This square wave signal can be sent directly to a PLC or other control or can be converted using any of the SeaMetrics family of indicators and converters.

A modular system of electronics can be attached directly to the flow sensor or remotely mounted. The SeaMetrics FT420 provides full indication of rate and total, plus 4-20 mA output. The A055 provides blind 4-20 mA output, while the FS30 can be used for a precise setpoint flow switch, and the DL75 is a battery-powered data logger. The EX100/200 Series is also compatible with the FT520 batching flow processor.

The adapter fitting of the EX sensor is standard male NPT, and can be directly threaded into ordinary saddles or threaded weld fittings. The EX115 and 215 include an isolation valve, allowing hot-tap installation, or installation and removal under pressure. On brass and stainless models, a bronze ball valve is standard, with a 316 stainless steel valve option if needed. PVC models have a gate valve.

SPECIFICATIONS

POWER

12 – 24 Vdc, 250 mA max

FLOW RANGE

0.2 – 20 ft/sec

FITTING SIZE

EX101/201B/S: 1.5" MNPT

EX101/201P: 2" MNPT

All EX115/215: 2" MNPT

TEMPERATURE

Brass/SS: Ambient 0–180° F (-17–32°C)

Fluid 32–200° F (0–93°C)

PVC: Ambient 0–180° F (-17–82°C)

Fluid 32–130° F (0–55°C)

PRESSURE

Brass/SS: 200 psi (13.8 bar)

PVC: 150 psi (10 bar) @ 75° F

MINIMUM CONDUCTIVITY

20 microsiemens/cm

CALIBRATION ACCURACY

1% of full scale

OUTPUT

Square wave pulse, Opto isolated

550 Hz @ 20 ft/sec

6 mA max, 30 Vdc

Forward Flow Standard

Reverse Flow Optional

EMPTY PIPE DETECTION

Software, defaults to zero flow

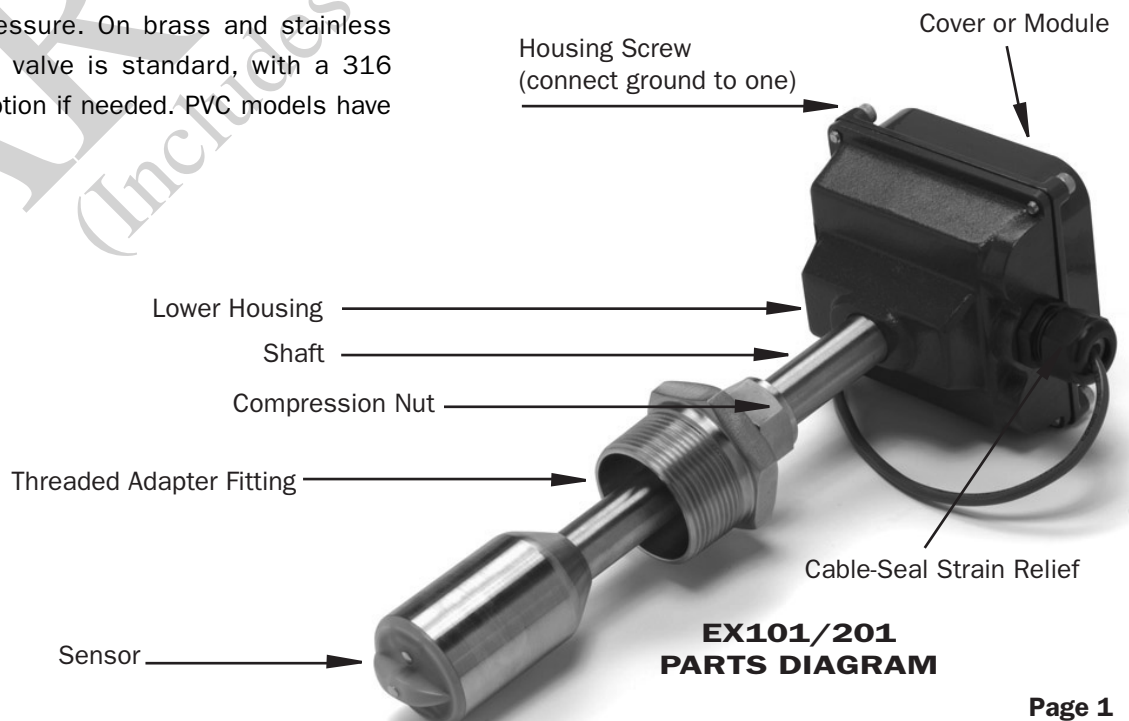

INSTALLATION

Piping. For best results, the EX sensor should be installed with at least ten diameters of straight pipe upstream and five downstream. Certain extreme situations such as partially-opened valves are particularly difficult and may require more straight diameters upstream.

DISTORTED FLOWS

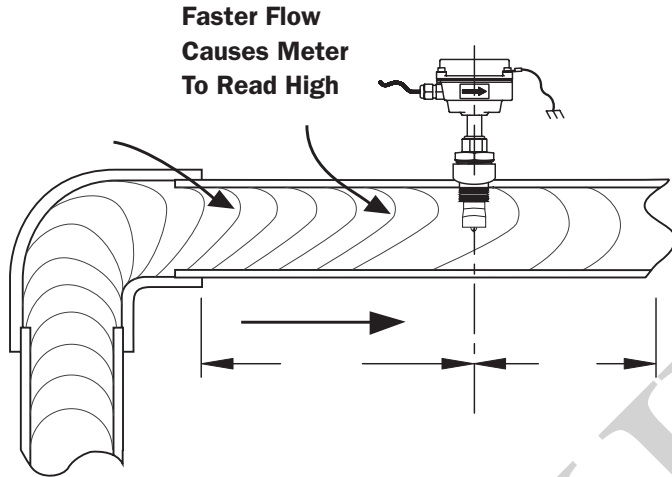

POSITIONING THE METER

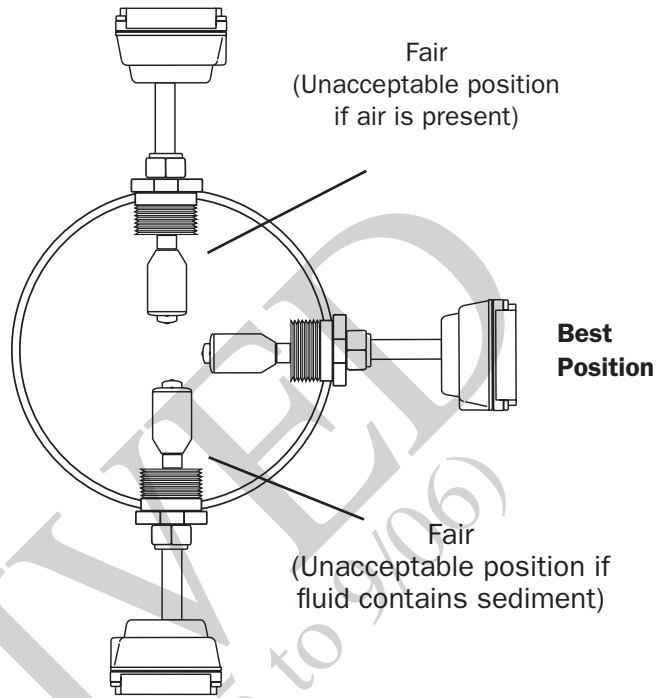

Immersion. The 100/200 Series standard sensors are not designed for continuous underwater operation. If this is a possibility, as in a flooded vault, a unit modified for immersion should be specified (Option -40).

Horizontal is the preferred installation orientation, since it improves low-flow performance and avoids problems with trapped air. Bottom, top, and vertical pipe installations are all acceptable if required by the piping layout.



Caution: These flow sensors are not recommended for installation downstream of the boiler feedwater pump where installation fault may expose the flow sensor to boiler pressure and temperature. Maximum recommended temperature is 130°F (Plastic), 200°F (Metal).

INSTALLATION

EX101/201 INSTALLATION

Fitting Installation. EX101/201 sensors come with a male NPT pipe thread adapter fitting (brass and stainless: 1 1/2"; PVC: 2"). Any fitting that provides the matching NPT female thread may be used. Installation procedure compensates for fitting height differences. Cut a minimum 1-3/4" hole in the pipe. If possible, measure the wall thickness and write it down for use in depth setting. Then install the threaded fitting (saddle, weldolet, etc.) on the pipe.

Meter Installation. Loosen the compression nut so that the adapter slides freely. Pull the meter fully upward and finger-tighten the compression nut. Using a thread sealant, install the adapter in the pipe fitting. Do not overtighten. Now loosen the compression nut, lower the meter to the appropriate depth setting (see diagram and instructions that follow). Be sure flow is in the direction of the arrow on the housing. Tighten compression nut fully.

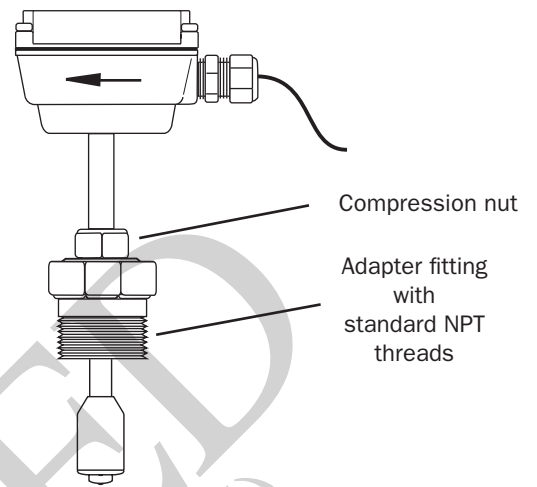

EX115/215 INSTALLATION

'Hot tap' EX meters are designed to be installed and serviced without depressurizing the pipe.

Fitting Installation. The EX 115 and 215 sensors have a 2" NPT thread for compatibility with the 2" isolation valve. Any fitting that provides matching NPT female thread may be used. The installation procedure compensates for differences in fitting height.

If initial installation is performed on an unpressurized pipe, cut a minimum 1-3/4" hole in the pipe. If possible, measure the wall thickness and write it down for use in depth setting. Then install the threaded fitting (saddle, weldolet, etc.) on the pipe.

If it is necessary to do the initial installation under pressure, any standard hot tap drilling machine with 2" NPT adapter, such as a Transmate or a Mueller, can be used. Ordinarily, it is not necessary to use an installation tool, since the small-diameter tube can be controlled by hand at all but the highest pressures.

Meter Installation. Remove the sensor unit from the valve assembly. Using a thread sealant, install the valve assembly on the pipe fitting. If the initial installation is a pressure ("hot") tap, remove the 1-1/2" x 2" adapter bushing at the back of the valve. Thread the tapping machine on, open the valve, and tap using a minimum of 1-3/4" or maximum 1-7/8" cutter. After retracting the machine and closing the valve, reinstall the flow sensor. When the sensor is secure, open the valve and adjust depth setting (see diagram and instructions that follow). Be sure flow is in the direction of the arrow on the housing. Tighten compression nut fully.

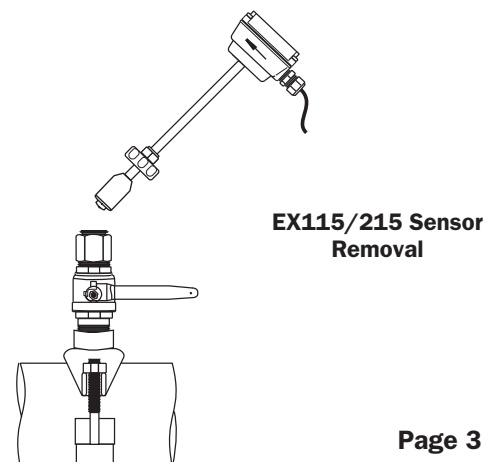
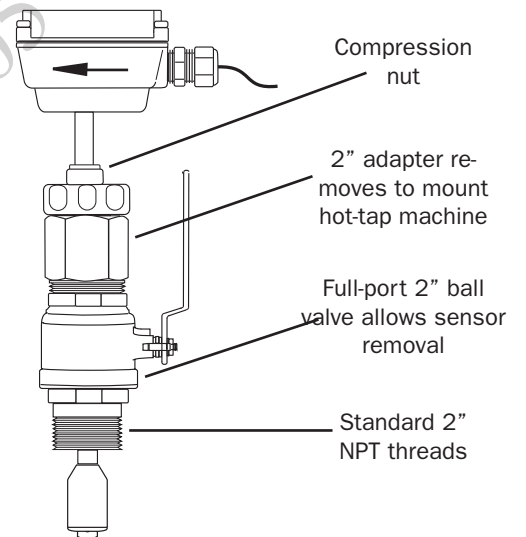

INSTALLATION

PROPER DEPTH SETTING

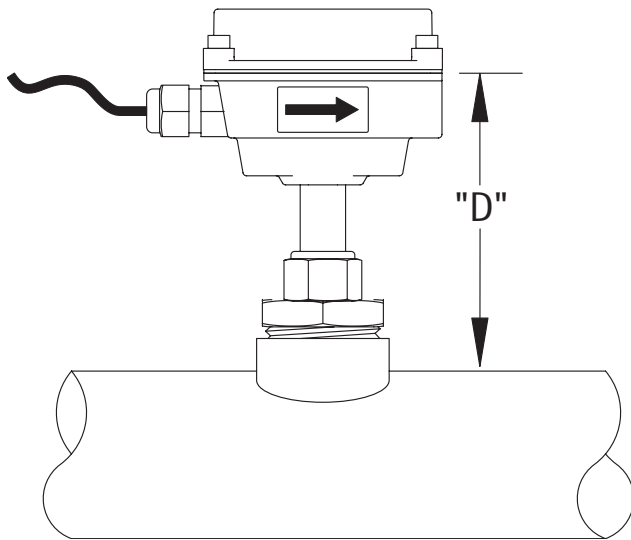

Caution! Never attempt to remove a flow sensor when there is pressure in the pipe. Loosen the compression nut slowly to release any trapped pressure. If fluid sprays out when removing the sensor, stop turning and depressurize the pipe. Failure to do so could result in the sensor being thrown from the pipe, resulting in damage or serious injury.

Depth Setting. It is important for accuracy that the sensor be inserted the correct depth into the pipe.

Follow these steps:

1. In Table 1, find Dimension C for your sensor model, material and pipe size.
2. Subtract wall thickness of your pipe to find Dimension D. Use Table 2 if you do not know the thickness.
3. Measuring from the outside of the pipe to the joint in the housing, as shown in the diagram, adjust the sensor to Dimension D and hand-tighten compression nut.
4. Align the conduit housing with the centerline of the pipe, as shown. Be sure the arrow on the housing points in the direction of flow.

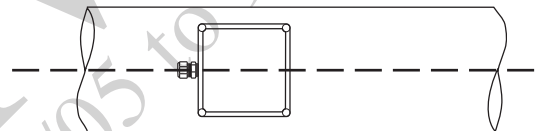

5. Check Dimension D one more time.
6. Tighten the compression nut fully.

INSTALLATION

TABLE 1: DIMENSION "C"

	NOMINAL PIPE SIZE												
	3"	4"	6"	8"	10"	12"	14"	16"	18"	20"	24"	30"	36"
EX101B/S	10.04	9.93	9.69	9.46	9.22	8.99	8.75	8.52	8.28	8.05	7.58	6.87	6.17
EX101PVC	12.04	11.93	11.69	11.46	11.22	10.99	10.75	10.52	10.28	10.05	9.58	8.87	8.17
EX201B/S	15.04	14.93	14.69	14.46	14.22	13.99	13.75	13.52	13.28	13.05	12.58	11.87	11.17
EX201PVC	17.04	16.93	16.69	16.46	16.22	15.99	15.75	15.52	15.28	15.05	14.58	13.87	13.17
EX115B/S	17.04	16.93	16.69	16.46	16.22	15.99	15.75	15.52	15.28	15.05	14.58	13.87	13.17
EX115PVC	19.04	18.93	18.69	18.46	18.22	17.99	17.75	17.52	17.28	17.05	16.58	15.87	15.17
EX215B/S	21.04	20.93	20.69	20.46	20.22	19.99	19.75	19.52	19.28	19.05	18.58	17.87	17.17
EX215PVC	23.04	22.93	22.69	22.46	22.22	21.99	21.75	21.52	21.28	21.05	20.58	19.87	19.17

TABLE 2: PIPE WALL THICKNESS

	3"	4"	6"	8"	10"	12"	14"	16"	18"	20"	24"	30"	36"
PVC/Steel Sch. 40	0.216	0.237	0.280	0.322	0.365	0.406	0.438	0.500	0.562	0.593	0.687		
PVC/Steel Sch. 80	0.300	0.337	0.432	0.500	0.593	0.687	0.750	0.843	0.937	1.031	1.218		
Stainless Steel (10S)	0.120	0.120	0.134	0.148	0.165	0.180	0.188	0.188	0.188	0.218	0.250	0.312	0.312
Stainless Steel (40S)	0.216	0.237	0.280	0.322	0.365	0.375	0.375	0.375	0.375	0.375	0.375	0.375	0.375
Copper Tubing (Type L)	0.090	0.110	0.140	0.200	0.250	0.280							
Copper Tubing (Type K)	0.109	0.134	0.192	0.271	0.338	0.405							
Brass Pipe	0.219	0.250	0.250	0.312	0.365	0.375							
Duct. Iron (Class 52)	0.280	0.290	0.310	0.330	0.350	0.370	0.390	0.400	0.410	0.420	0.440	0.470	0.530

INSTALLATION

STRAIGHT PIPE RECOMMENDATIONS

(X = diameter)

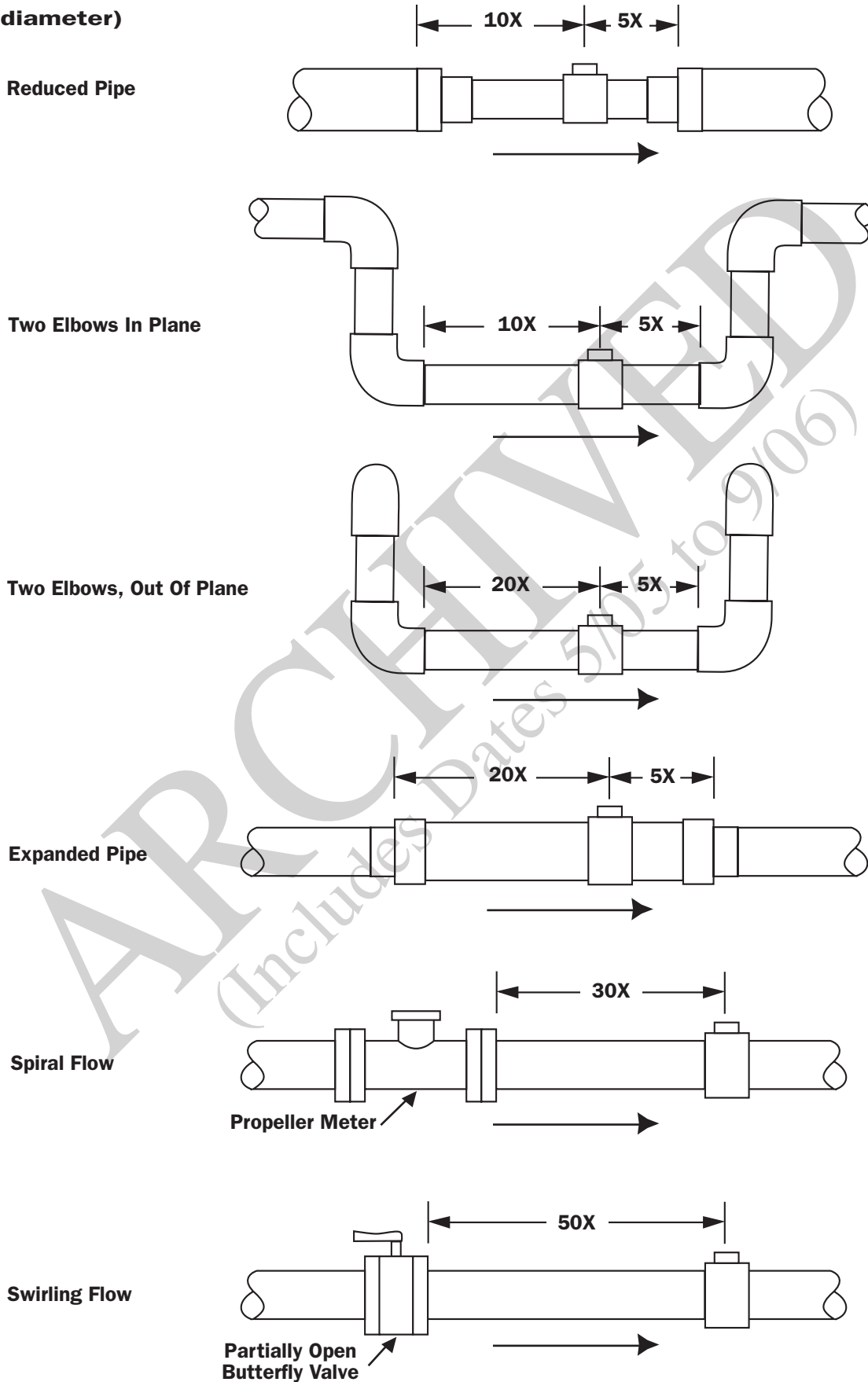

INSTALLATION

FULL PIPE RECOMMENDATIONS

NOT RECOMMENDED

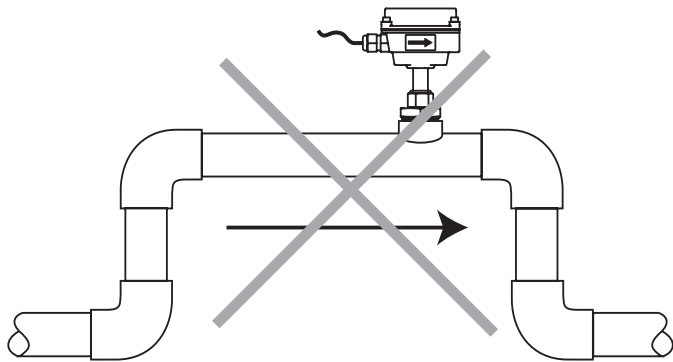

Allows air pockets to form at sensor

RECOMMENDED

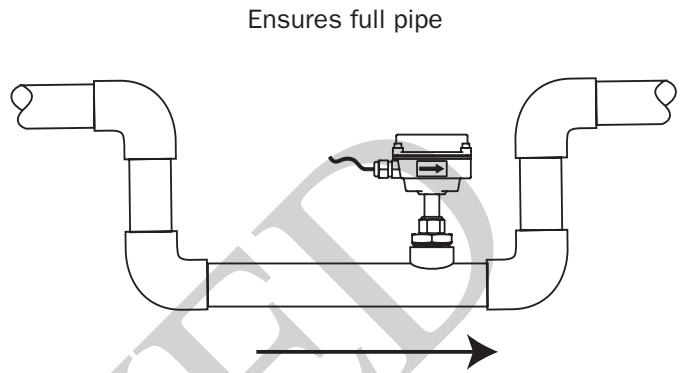

NOT RECOMMENDED

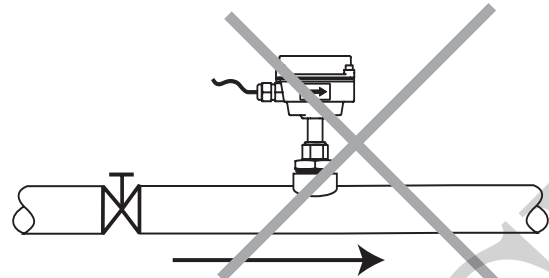

Post-valve cavitation can create air pocket

RECOMMENDED

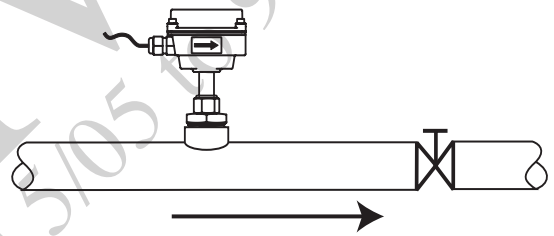

Keeps pipe full at sensor

NOT RECOMMENDED

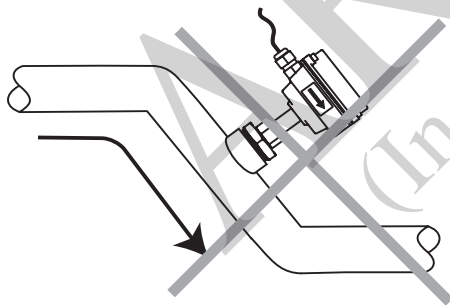

Air can be trapped

RECOMMENDED

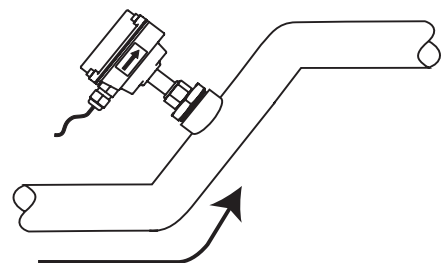

Allows air to bleed off



Caution: These flow sensors are not recommended for installation downstream of the boiler feedwater pump where installation fault may expose the flow sensor to boiler pressure and temperature. Maximum recommended temperature is 130°F (Plastic), 200°F (Metal).

ELECTRICAL CONNECTIONS

General Electrical Guidelines:

- Whenever possible avoid running control cables in the same conduit with AC power.
- Using shielded cable, be sure that one end is grounded.
- Avoid routing flow sensor cables in close proximity to a variable frequency drive.
- Recommended power and output wiring is shielded 18-22 AWG control cable.
- Recommended voltage is 12-24 VDC. Note that unregulated power supplies can vary from nameplate voltage by a considerable amount. When in doubt, use a regulated power supply.

See the Connections diagrams on the following pages for the appropriate terminals.

Power: A 12 - 24 Vdc power supply capable of at least 250 mA current output is needed.

Forward Flow Output: This open-collector isolated output does not supply power. It functions like a polarity-sensitive switch closure. This pulse is generated in the forward flow direction on the standard unit. (Reverse flow output is available as an option).

Note: This output is limited to 6 mA at 30 Vdc maximum.

Reverse Flow Output: Reverse flow output is available as an option. This open-collector isolated output does not supply power. It functions like a polarity-sensitive switch closure.

Note: This output is limited to 6 mA at 30 Vdc maximum.

Grounding Guidelines:

For best results, use a good quality earth ground, such as metallic water piping, or a stake driven into the ground.

If the flow sensor is installed in metallic piping, for optimum grounding clamp wires to the piping a short distance to either side of the flow sensor using hose type clamps. Connect these wires to the earth ground and to one of the housing screws. (For non-metallic piping, this step is not needed.)

EX meters are usually unaffected by moderate levels of electrical noise. In some applications performance may be improved by taking the following steps:

- Use shielded twisted pair cable (Belden 8723 or equivalent above ground or Alpha 35482 or equivalent burial).
- Clamp a ferrite bead (Steward 28A2029-OAO or equivalent) on meter signal/power wire within 3/4" of the meter strain relief (tape or tie wrap in place if necessary). See diagram below.
- **IMPORTANT** - Connect the cable shield ground wire to ground, ONLY at power supply end of cable.

GROUNDING DIAGRAM

(Not needed for non-metallic pipe)

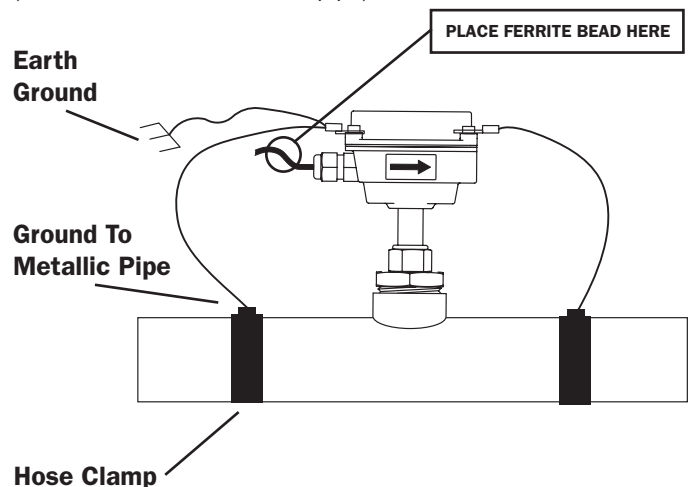

CONNECTIONS DIAGRAMS

COUNTER OR PLC

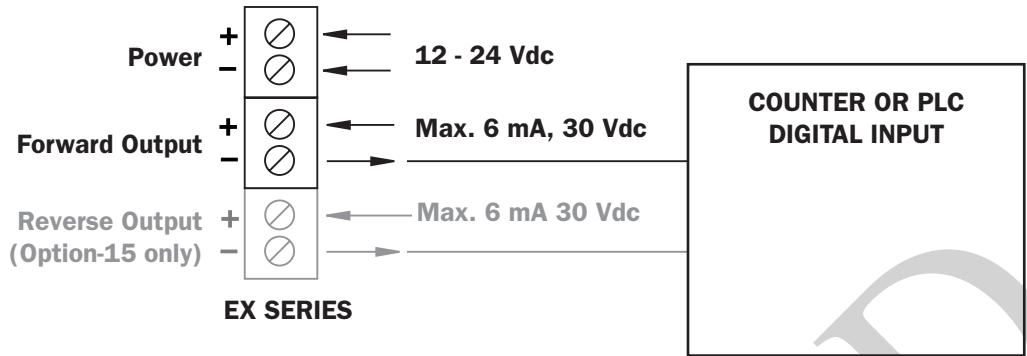

*See Dual FT420 Diagram for an example of bidirectional connections.

A055 4-20 mA OUTPUT

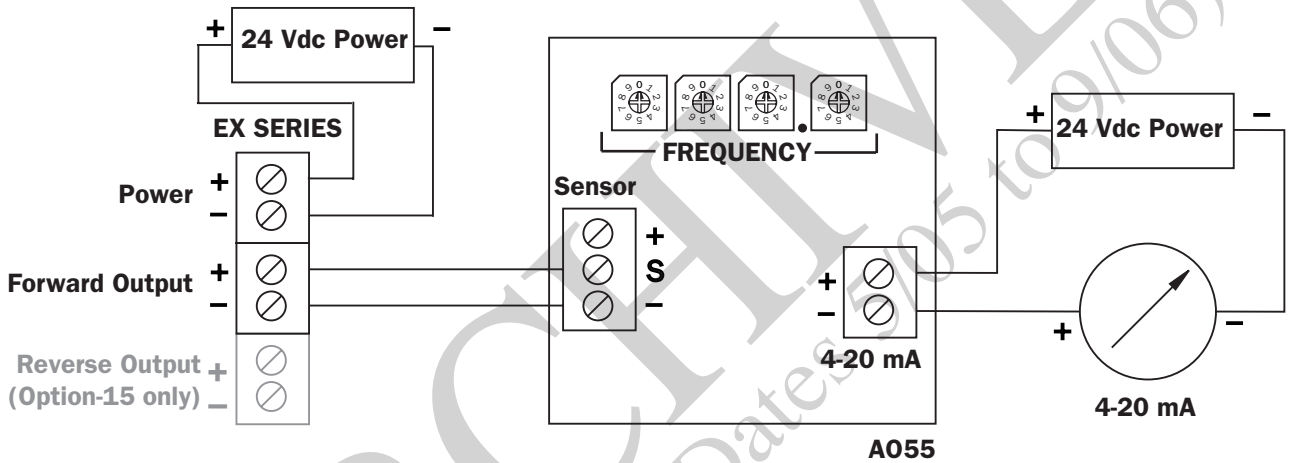

*See Dual FT420 Diagram for an example of bidirectional connections.

FT520 CONTROLLER

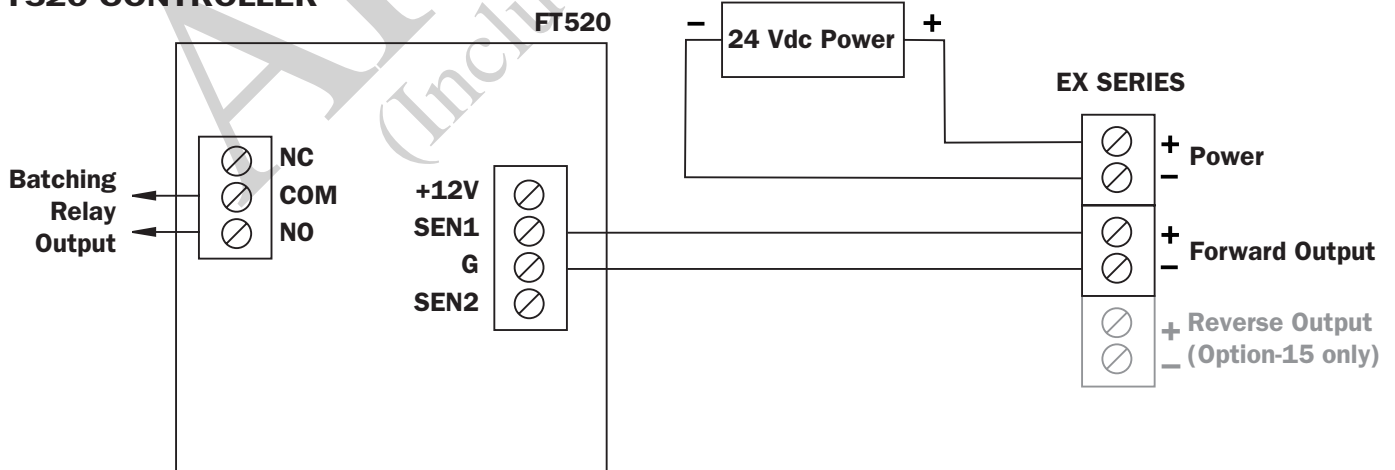

*See Dual FT420 Diagram for an example of bidirectional connections.

CONNECTIONS DIAGRAMS

FT420 DISPLAY AND PROPORTIONAL FEED

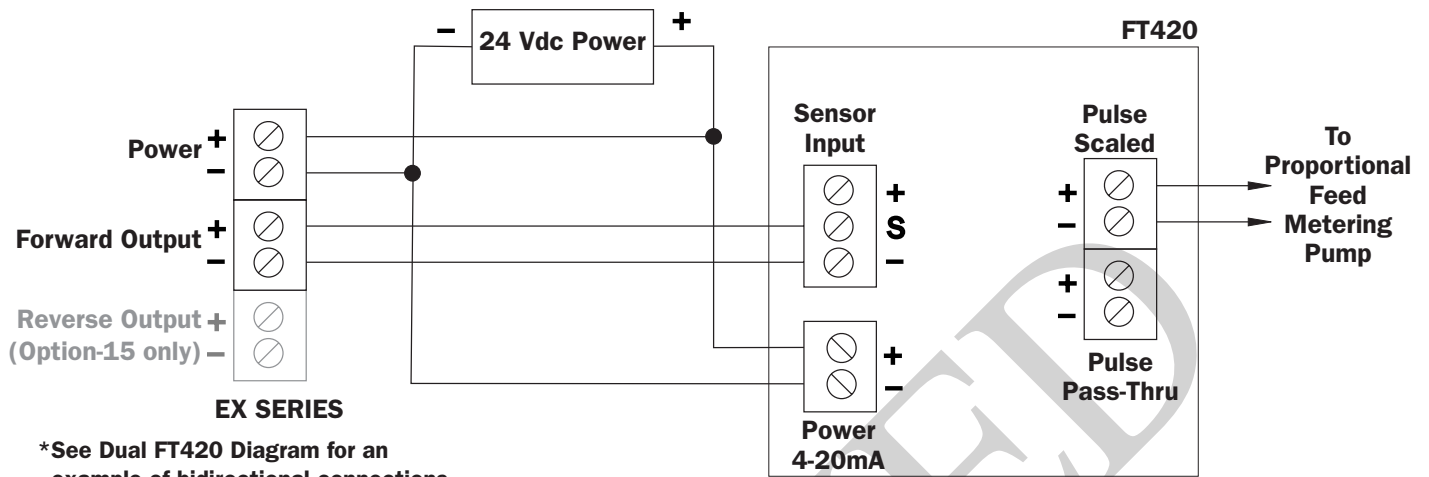

*See Dual FT420 Diagram for an example of bidirectional connections.

FT420 DISPLAY AND 4-20 mA OUTPUT

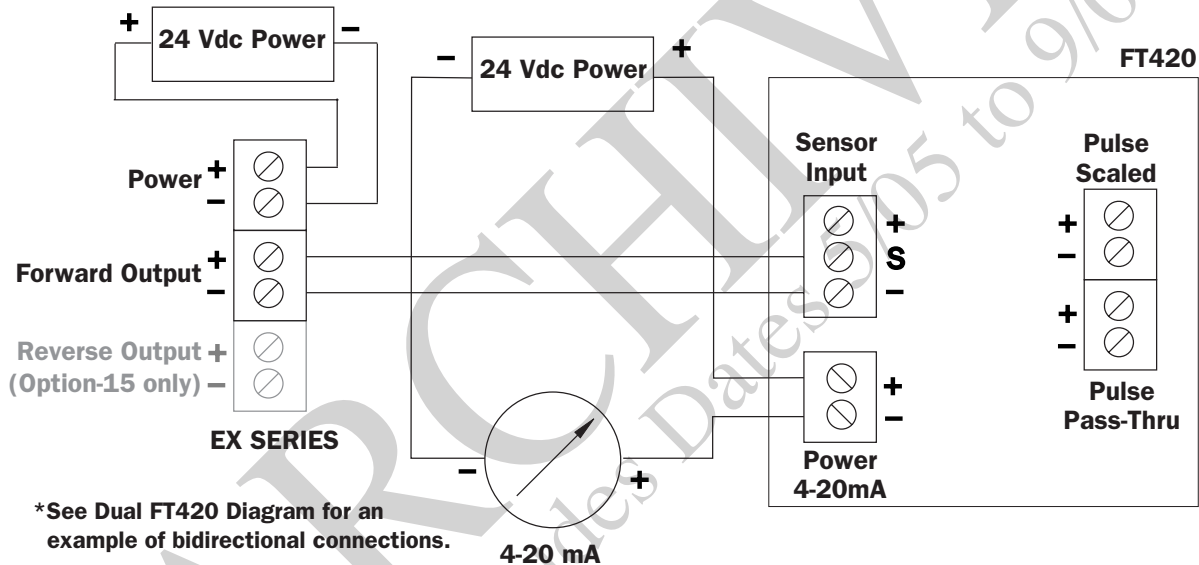

*See Dual FT420 Diagram for an example of bidirectional connections.

FS30 FLOW SWITCH

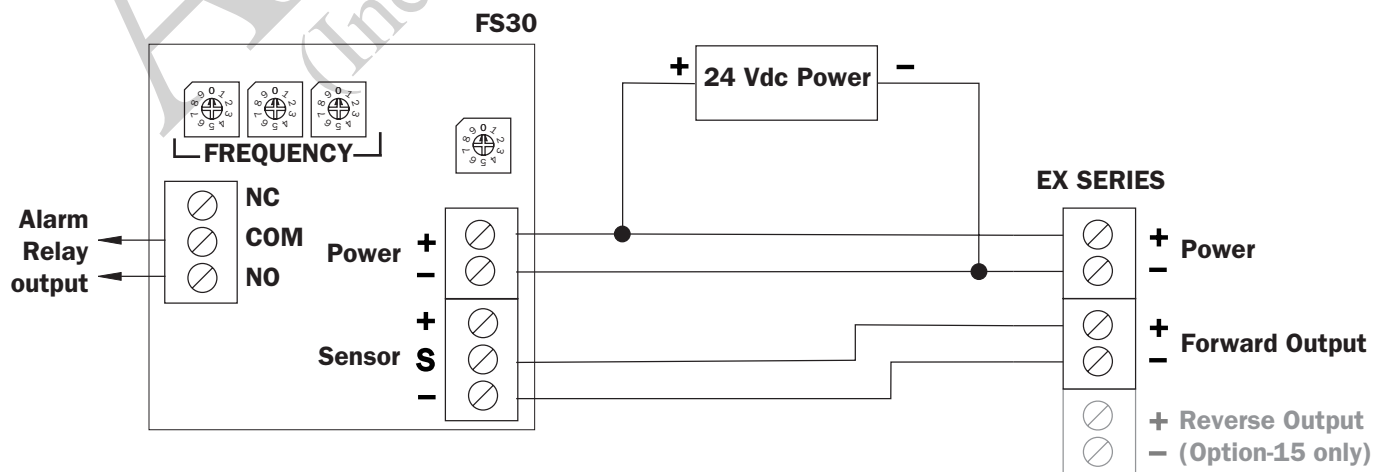

*See Dual FT420 Diagram for an example of bidirectional connections.

CONNECTIONS DIAGRAMS

DL75 DATA LOGGER

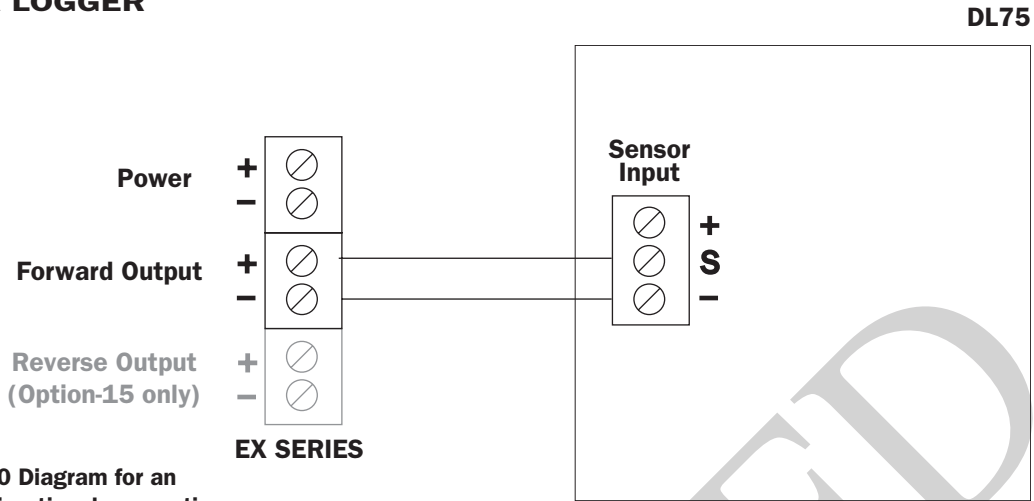

*See Dual FT420 Diagram for an example of bidirectional connections.

FT420/DL75

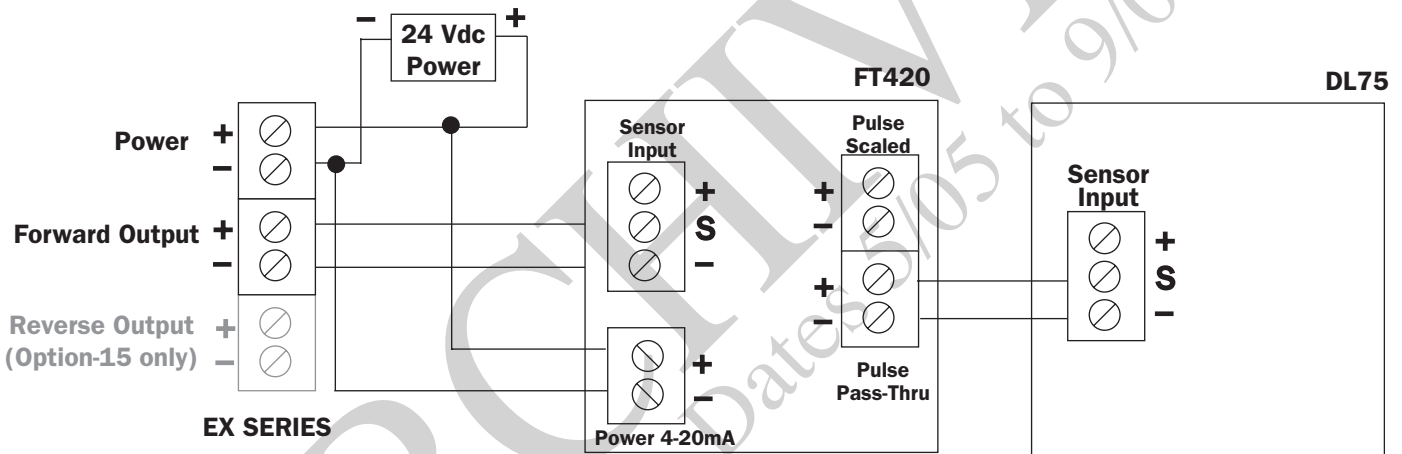

*See Dual FT420 Diagram for an example of bidirectional connections.

DUAL FT420 DISPLAYS (Example of Bidirectional Connection)

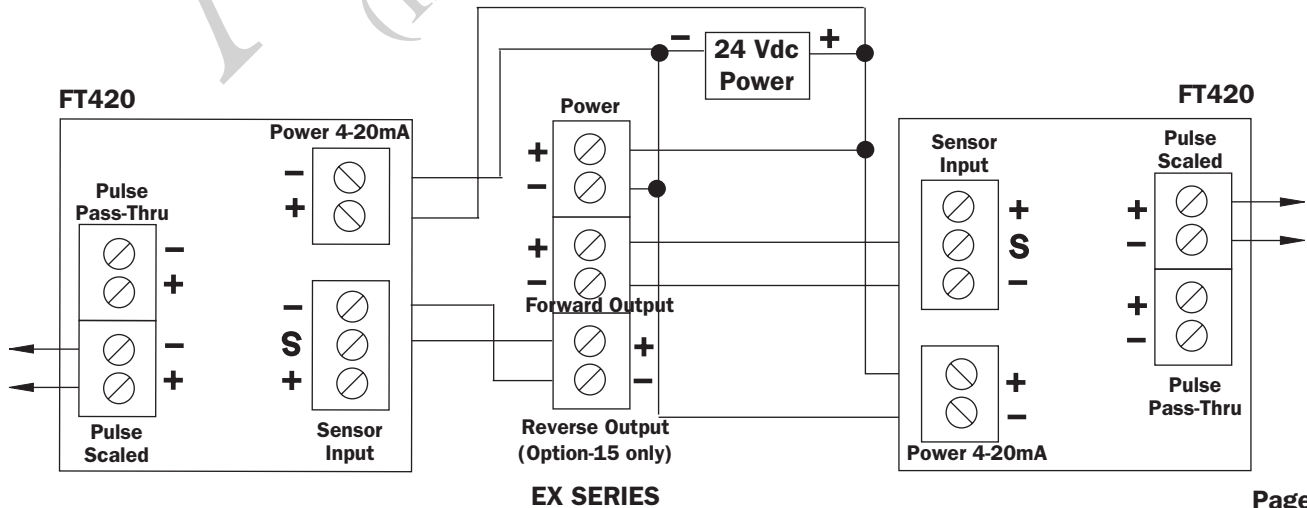

OPERATION & MAINTENANCE

Zero Adjustment. When the EX100/200 Series meter is powered up and there is no flow, there should be no output pulses (or, if connected to the FT420, flow rate should read “0”). If there are pulses it may be necessary to adjust the flow meter under no-flow conditions after it has been installed. This should only be done if the indicated flow is low, near the lower cutoff.

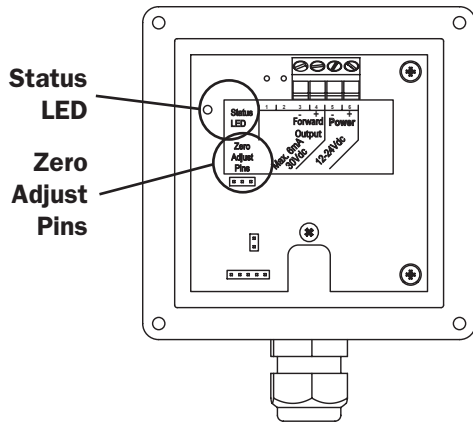

To perform the adjustment, after determining that there is a full pipe with no flow, short between the two pins marked “Zero Adjust”. A red LED light will come on for approximately 50 seconds and then go out. The zero adjustment is completed.

Minimum Flow. As with any other flow sensor, there is a rate below which the EX100 Series sensor cannot read. Check the table on page 13 for the minimum flow rate detectable by the sensor (at 0.2 ft/sec) for a given pipe size.

Presence of Flow Indication. To assist in troubleshooting, the “Status LED” has two blinking modes in normal operation. When there is no flow detectable by the meter (below minimum threshold) the LED blinks every 8.0 seconds. When there is detectable flow, the same indicator blinks every 3.0 seconds.

Filtering. The software of the EX100/200 Series filters out electrical noise and averages sudden variations in the flow to smooth the output. It takes a matter of seconds for the flow sensor to get up to full output when it is powered up or when flow begins.

Electrode Coating. Grease or other adhering, non-conductive materials can stop flow detection if the electrodes become heavily coated. To clean the electrodes, remove the sensor from the pipe and gently scrub the electrodes (three silver bumps) on the reading face of the flow sensor. A mild soap (dishwashing liquid for example) can be used to aid the cleaning process.

Calibration (“K-Factor”). In order to properly process pulses from the flow sensor, a number must be entered into the control to which the sensor is connected. This number, called the K-factor, is the number of pulses the sensor puts out per unit of fluid passing through the pipe. It is normally provided for SeaMetrics sensors in pulses per gallon, and is given on the chart “K-factors for Various Pipe Sizes” on page 13. These numbers are based on extensive testing, which has shown close agreement between different EX sensors in the same installation. Typically, most K-factor error can be attributed to installation variables, such as depth setting and fitting configuration.

OPERATING CHARTS

MINIMUM AND MAXIMUM FLOW RATES IN GALLONS PER MINUTE													
Feet Per Second	NOMINAL PIPE SIZE												
	3"	4"	6"	8"	10"	12"	14"	16"	18"	20"	24"	30"	36"
(0.2)	4.5	8	18	31	49	70	96	125	159	196	282	440	635
(20.0)	440	783	1762	3133	4895	7050	9596	12533	15863	19584	28200	44064	63452

EX SERIES K-FACTORS FOR VARIOUS PIPE SIZES													
	NOMINAL PIPE SIZE												
	3"	4"	6"	8"	10"	12"	14"	16"	18"	20"	24"	30"	36"
PVC/Steel Sch. 40	70.397	40.985	18.130	10.497	6.674	4.709	3.900	2.989	2.364	1.904	1.319		
PVC/Steel Sch. 80	78.748	45.360	20.084	11.495	7.322	5.184	4.297	3.281	2.588	2.094	1.451		
Stainless Steel (10S)	62.385	36.626	16.510	9.642	6.173	4.373	3.620	2.756	2.169	1.762	1.223	0.784	0.576
Stainless Steel (40S)	70.397	40.985	18.130	10.497	6.674	4.661	3.827	2.893	2.263	1.819	1.249	0.791	0.580
Copper Tubing (Type L)	76.371	43.552	19.513	11.201	7.230	5.016							
Copper Tubing (Type K)	78.371	44.638	20.223	11.622	7.500	5.239							
Brass Pipe	70.672	41.517	17.778	10.445	6.674	4.661							
Duct. Iron (Class 52)	57.376	37.320	16.915	9.503	6.197	4.325	3.189	2.443	1.931	1.565	1.088	0.747	0.520

Note: These K-Factors are calculated using actual pipe diameters and wall thicknesses for each pipe type. They are based on the most current testing at the time of printing. Refer to the SeaMetrics K-Factor Calculator at www.seametrics.com for the most precise and current calculations.

TROUBLESHOOTING

Problem	Probable Cause	Try...
No pulse output	Unit not grounded	Connect to earth ground
	Below minimum flow cutoff	Check the Presence of Flow LED (see pg. 12)
	Flow reversed	Note flow direction arrow, reverse direction to meter
	Output connections reversed	Change output connections
	Pipe not full	Check plumbing
	Excessive electrical noise	Check for proper electrical wiring
	No power	Check for power across power input terminals
	Power reversed	Reverse connections
	Fluid conductivity <20 microSiemens/cm	Select another flow meter
Output pulses incorrect	Missing or incorrect ground wire	Check for proper ground
	Incorrect depth setting	Check depth setting from Dimension "C" table (page 4)
	Fluid conductivity <20 microSiemens/cm	Select another flow meter
	Empty pipe	Check for full pipe or install meter in the vertical position
	Not enough straight pipe	Check chart on page 2
	Not enough straight pipe	Check for air pockets or turbulence. Refer to installation, page 2
	Excessive electrical noise	Check for proper electrical wiring



19026 72nd Ave South, Kent, WA 98032 USA
(P) 253.872.0284 (F) 253.872.0285
www.seametrics.com 1.800.975.8153