

WTP

PVC BODY TURBINE METER INSTRUCTIONS



PVC BODY TURBINE METER INSTRUCTIONS

ISO 9001:2000
CERTIFIED

SeaMetrics

The Leader in Flow Meter Value

GENERAL INFORMATION and SPECIFICATIONS

GENERAL INFORMATION

This unique system of 2" to 6" turbine meters uses one moving part, a precision helical rotor. Rotation of the rotor is electronically detected and processed. High-quality jewel bearings and polished zirconia ceramic shafts minimize friction while providing long wear life in non-lubricating fluids. The entire rotor assembly can be easily removed for field service without removing the meter from the pipe.

WTP bodies are fabricated from Schedule 80 PVC fittings. The turbine inset is machined from a solid piece of PVC (polypro in 2" size). The turbine rotor is Kynar (PVDF).

WTP meters can be ordered with a number of input and output options. The basic model comes with pulse output only. An electronic display (identical to the SeaMetrics FT420) can be mounted on the meter to display flow rate and total (resettable or non-resettable), and provide programmable pulse output. Other electronics options include the AO55 blind 4-20 mA transmitter and the battery-powered (FT415) rate/totalizer for applications that lack power. All of these controls/displays can be mounted on the meter or remotely mounted on a wall or panel up to 2,000 feet away. The WTP is compatible for use with most other remote-mount SeaMetrics displays and controls as well.

PRESSURE VS. TEMPERATURE

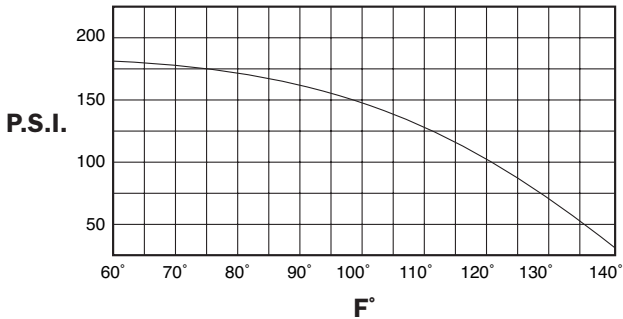

PRESSURE LOSS CHART

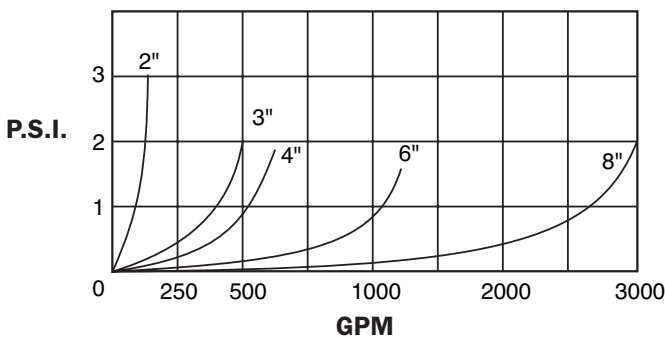

SPECIFICATIONS

Power	Depends on model, see below			
Materials Body	PVC schedule 80 fittings			
Turbine Insert	PVC (Polypro in 2" size)			
Rotor	Kynar (PVDF)			
Shafts	Zirconia Ceramic			
Bearings	Sapphire journal, ruby endstone			
Maximum Pressure	150 psi @ 75° (10 bar @ 24° C)			
Maximum Temperature	120° F (50° C)			
Accuracy	+/- 1% of full scale			
Flow Range (GPM)	2"	3"	4"	6"
Minimum	2	3	6	12
Maximum	150	400	600	1200

ELECTRONIC OPTIONS

WT100 (Pulse Only)	
Power	6-24 Vdc
Pulse Type	Current sinking
WT101 (Powered Rate/Totalizer) (e.g. FT420)	
Power	12-32 Vdc; 4 mA DC (4-20 mA loop)
Rate	6-digit autorange
Total	8-digit
Memory	Non-volatile (no battery needed)
Pulse Output	0.1 second, open collector
Pulse Range	0.1 - 9999999.9 units per pulse
Analog Option	4-20 mA, user-programmed, span, two wire
WT102 (Blind 4-20 mA Transmitter) (e.g. AO55)	
Power	24-36 Vdc (isolated)
Output	Proportional 4-20 mA loop
Response Time	2-60 seconds, 90% of full scale (depends on input averaging)
WT104 (Battery-Powered Rate/Totalizer) (e.g. FT415)	
Power	Lithium "C" 3.6 Vdc, replaceable, 3-5 year life
Rate	6-digit auto range
Total	8-digit

INSTALLATION

Piping Conditions. Installing the meter with 10 diameters of straight pipe upstream and 5 downstream is recommended.

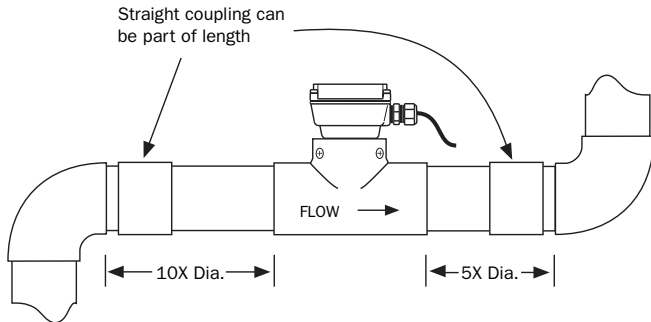

Flanges. Install PVC meters with optional flanges according to the pipe manufacturer’s recommendations. A bolt torque of 10-20 ft. lbs. for flanges 1-1/2” and 2”, 20-30 ft. lbs. for flanges 3” and 4”, and 35-50 ft. lbs. for flanges 6” is recommended. Tighten the bolts evenly. Either partial or full-face gaskets can be used. Use care to prevent a misaligned gasket from entering the flow stream.

Position. The WT-Series are all-position meters, and can be operated in a vertical or horizontal position, and with the meter insert in any radial position. A horizontal position is preferred if there is a risk of air becoming trapped due to constant low flows. Operating the meter in partially-filled pipe will result in inaccuracies.



CAUTION: These water meters are not recommended for installation downstream of the boiler feedwater pump where installation fault may expose the meter to boiler pressure and temperature. Maximum recommended temperature is 120° F.

CONNECTIONS

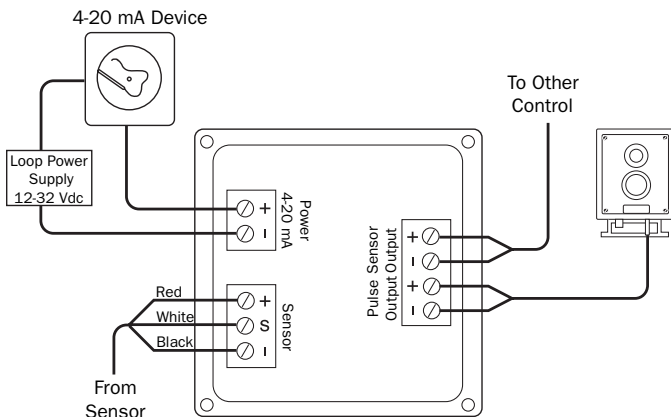

OPERATION

For operating instructions for the various electronic modules, consult the manual for the specific module, included with the meter at purchase.

MAINTENANCE and REPAIR

Recalibration. If it is necessary to recalibrate the meter for any purpose, this can be done by any SeaMetrics-authorized facility. Call the factory for information.

Turbine Insert Removal and Installation. First remove all pressure from the line. Then remove the screws that hold the insert in place and tug gently on the insert until it comes free. A twisting motion can help to loosen the O-ring seal. Reverse the procedure to reinstall, after coating the O-ring with a plastics-compatible lubricant. Do not overtighten the screws. Snug tightening with a hand screwdriver is sufficient.

Rotor and Shaft Replacement. Examine the rotor to determine if bearings or shaft are damaged or excessively worn. The rotor should spin smoothly and freely, with no visible wobble. Back and forth play should be very minor, less than 1/64”. If it is necessary to replace the rotor or shafts, first back out both shafts with a small blade screwdriver. The rotor will come free as soon as the shaft ends come free of the rotor bearings. **Note:** Do not overtighten the shaft screws. Check to be sure that a small amount of free play between the shaft ends and the bearings remains.

Sensor Replacement. This is rarely necessary. However, certain electrical conditions can damage the sensor. To replace it, first remove the electronics module. Disconnect the three sensor leads from the electronics module terminals and remove the threaded plug over the sensor. Finally, remove the sensor by pulling on the sensor leads. A gentle tug should be sufficient. Reverse the process to replace the sensor.

Electronics Module Repair. None of the electronics modules have replaceable components. Printed circuit boards must be replaced as complete units. In order to replace an entire electronics module, loosen the four retaining screws and the unit will lift free from the insert housing.

REPLACEMENT PARTS

WTP PARTS LIST & METER ASSEMBLY

WTP Parts - 2"		
1-6	Housing (same as 3-6")	see below
7	Strain relief	07655
8	Square housing adapter	N/A
9	Sensor retaining screw	25321
10	Sensor, low power	26310
11	O-ring, EPDM	25081
12	Shaft assembly, ceramic	16710
13	Turbine rotor, PVDF	25947
14	U-clip	15527

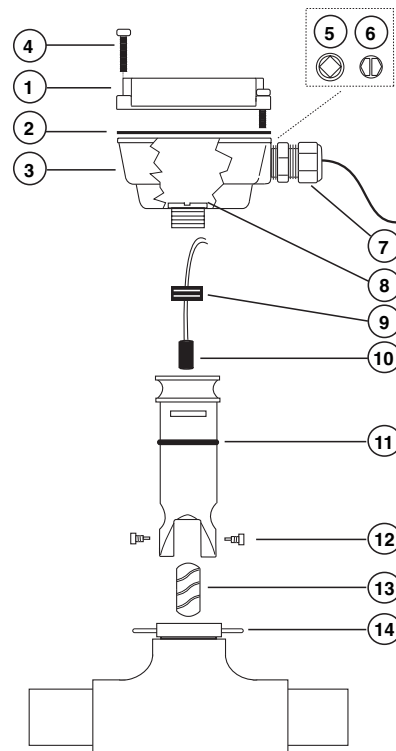

WTP Parts - 3"-6"		
1	Upper blind housing	30475
1	Powered rate/totalizer (e.g. FT420)	26949
1	Blind 4-20 mA transmitter (e.g. AO55)	26521
1	Battery-powered rate/totalizer (e.g. FT415)	26519
2	Lower housing gasket	26211
3	Lower housing	29930
4	Upper housing screw assembly	26229
5	Plug, steel	26073
6	Water seal assembly	26079
7	Strain relief	07655
8	Square housing adapter	N/A
9	Sensor retaining screw	25321
10	Sensor, low power	26310
11	Insert (3")	16830
11	Insert (4" - 6")	16850
12	Shaft assembly, ceramic	16710
13	O-ring, EPDM	16426
14	Turbine rotor, PVDF	25962
15	Insert screw (4)	07689

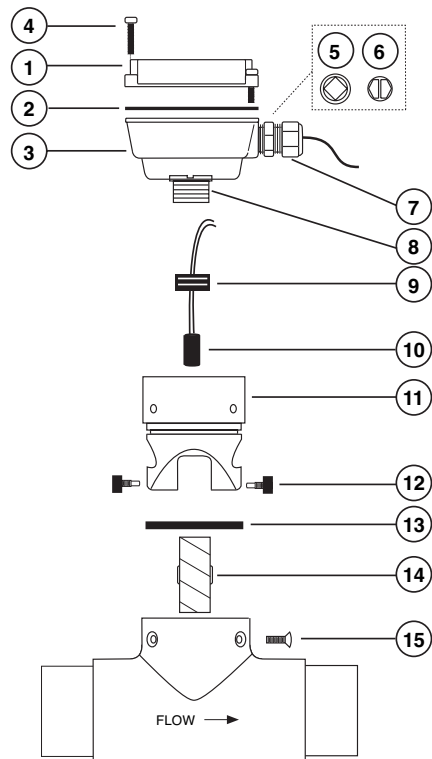

SeaMetrics Incorporated • 19026 72nd Avenue South • Kent, Washington 98032 • USA
 (P) 253.872.0284 • (F) 253.872.0285 • 1.800.975.8153 • www.seametrics.com