

Use of a SeaMetrics flow meter to control a metering pump is called "flow pacing" or "flow proportional feeding". The main flow (usually of water) is monitored by the flow meter, which in turn controls a metering pump. In this way, a chemical can be injected at a rate which matches the flow, for uniform concentration. Flow pacing can be done in one of four ways:

- Pulse meter and pulse-responsive pump
- Flow meter, counter/timer, and continuous-running pump
- Flow meter with 4-20 mA current loop signal, pump equipped for current loop
- Pulse meter or flow meter, divider, pulse-responsive pump

The following sections explain each of these in more detail.

### Pulse Meter and Pump

The simplest and most common approach is to use a "pulse-responsive" metering pump with a pulse meter. In the LMI line, this would be any of the following model series:

A7 Series, A9 Series\*  
 B7 Series, B9 Series\*  
 C7 Series, C9 Series\*  
 E7 Series

\*See the special section on A-, B-, and C-9 pumps

In this approach, the meter generates pulses proportional to the volume of water, and the pump strokes once for each pulse. SeaMetrics fixed pulse rate meters are the M-Series and WP meters.

**Connector.** The LMI pump requires a connector for external pacing. Any ME meter can be ordered with this connector pre-installed. The LMI connector is ordered by adding the option number -06 to the end of the model number.

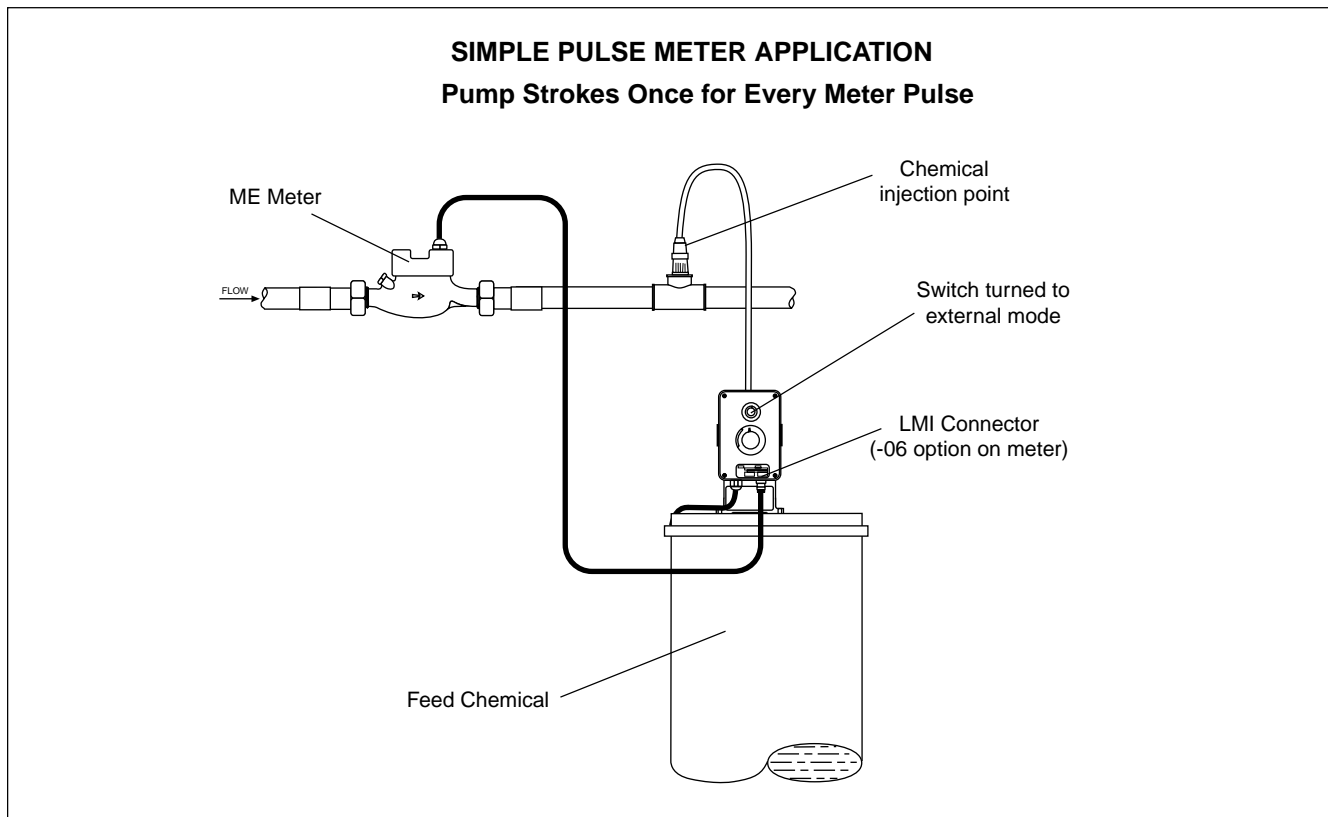

**Pulse Rate.** M Series meters are ordered with the desired pulse rate preset. The pulse rate can be modified on site, following instructions in the meter manual, but this requires removal of the meter top. It is much more convenient to order the correct rate in advance.

To determine the ideal pulse rate, after selecting the pump (using guidelines given in the LMI literature) follow these calculations:

$$\text{Ideal Pulse Rate (G/P)} = \text{Pump Max. Output (GPH)} \times \frac{\text{Chem Concentration (\%)}}{\text{Desired Dilution (PPM)}}$$

**Note 1:** This calculation has the ideal 60% stroke setting already built into it.

**Note 2:** If the result is less than one, divide one by the number to get Pulses/Gallon.

**Example:** The pump selected is an A74. From Table 1 or LMI literature, the maximum output of this pump is 0.58 GPH. The chemical being pumped is a 5% concentration of sodium hypochlorite. The desired end result is 2.0 parts per million of chlorine in water.

$$\text{Ideal Pulse Rate} = 0.58 \text{ (max GPH)} \times \frac{5 \text{ (conc. of chem.\%)}}{2 \text{ (PPM target)}} = 1.45 \text{ Gallons/Pulse}$$

The exact rate is not possible using an M Series meter, but a 1 G/P meter can be used, and the stroke adjusted down to make up the difference. Alternatively, a meter plus divider can be used to set the exact number. (See next section)

**Table 1: Maximum Outputs of LMI Pulse-Responsive Pumps, GPH**

Pump Model	Max (GPH)	Pump Model	Max (GPH)	Pump Model	Max (GPH)
Series A		Series B		Series C	
A74	0.58	B71	1.6	C70	1.3
A75	1.00	B72	2.5	C71	2.5
A76	2.00	B73	4.5	C72	4.0
A77	0.42	B74	7.0	C73	8.0
A78	0.75			C74	20.0
				C77	10.0
				C78	25.0

## Meter, Divider, and Pump

This approach uses an electronic divider to adjust the pulse rate. In this way, the ideal pulse rate can be used, and can also be adjusted as needs change. Also, higher-output flow meters (such as the SeaMetrics IP paddlewheel series) can be used.

There are two kinds of dividers, external and internal. All A9-, B9-, C9-, and E9- pumps have built-in microcontroller-based dividers, which are programmed at the pump. For other pulse-responsive pumps, the SeaMetrics PD10 serves the same function externally. The FT420 flow indicator can also be used. It adds display of rate and total flow to a programmable divider function.

A divider counts pulses and strokes the pump once when the preset “divider factor” is reached. The meter selected should have a higher pulse rate than the rate needed for the pump, to allow adjustment of the divider number.

## Meter, Counter/Timer, and Pump

This approach uses a simple on/off pump, and may be the most economical approach if a higher-volume chemical output is needed. To match chemical feed to flow,

### How To Determine Accumulator Setting(s):

If the meter pulses once every gallon, set the accumulator for the number of gallons desired between timer cycles. For meters with multiple pulses per gallon, multiply the desired number of gallons by the pulses per gallon. For meters with multiple gallons between pulses, divide the desired gallons by the gallons per pulse.

#### Example:

The goal is one timer output every 60 gallons. The meter has a 5 gallons per pulse (G/P) output.

$$\frac{60 \text{ gallons}}{5 \text{ gallons/pulse}} = 12 \text{ (accumulator setting)}$$

### How to Determine Timer Setting(s):

The timer setting is based on the desired amount of chemical to be fed and is specific to the pump. When calculating the time be sure it isn't more than the expected time between cycles, to avoid overlapping. Check by calculating:

$$\frac{\text{Cycle Size (Gallons)}}{\text{Max. Flow Rate (GPM)}} = \text{min. between cycles}$$

$$\times 60 = \text{sec. between cycles}$$

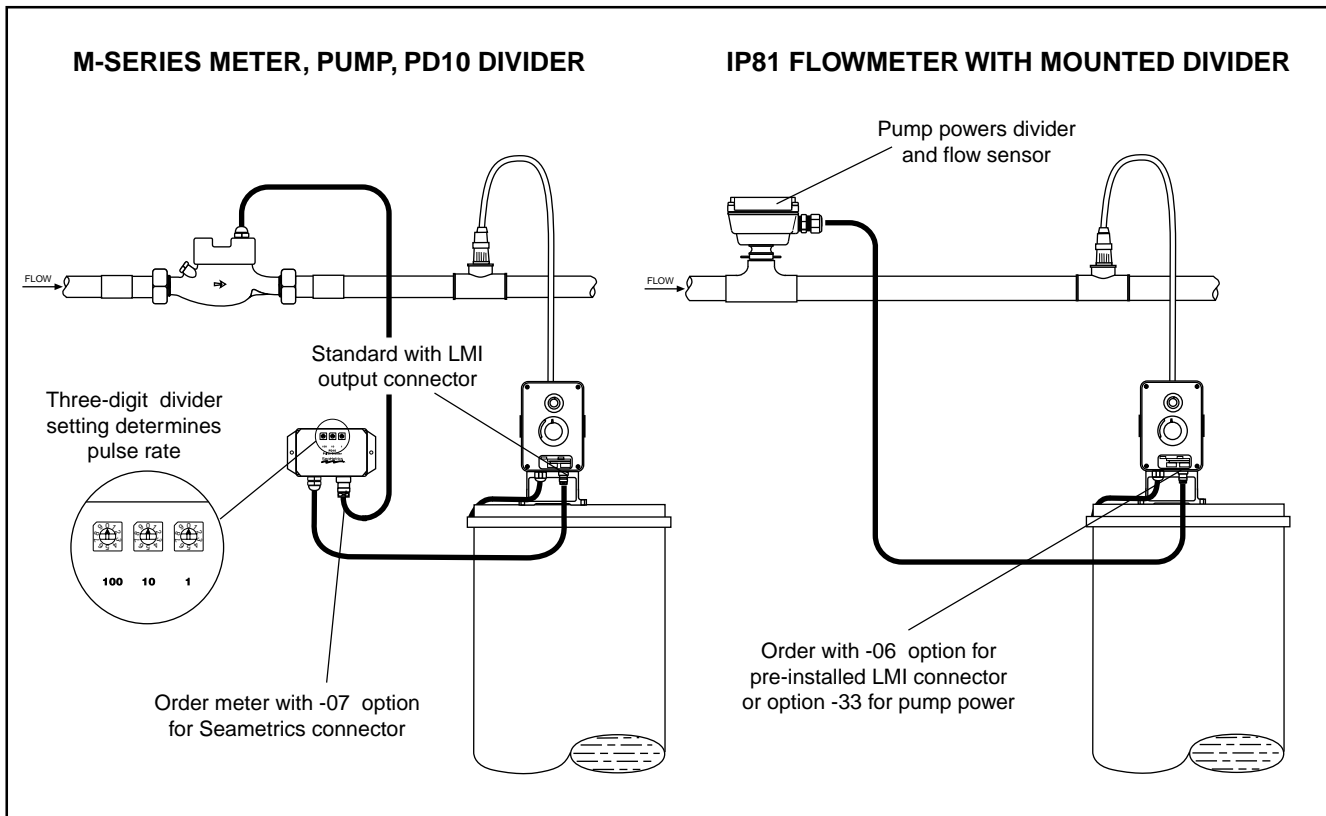

an additional control unit is used. This unit, a counter/timer, counts pulses from the meter. When a preset number of pulses has been counted, the timer turns on the metering pump and keeps it on for a set amount of time. Since the result is an on-off chemical flow, or "slug feed", there must be enough mixing capacity in the system to even out chemical concentration before the point of first use. One popular application is the feeding of treatment chemicals into a cooling tower system. The cooling tower tank typically provides plenty of opportunity for mixing before cooling water enters the piping system.

The SeaMetrics single counter/timer is designated the PT34. A double counter/timer, model PT35 can be used to control two different pumps or one pump and one valve.

### Flow Meter and Pump on 4-20 mA Current Loop

In this system, a standard 4-20 mA analog signal is transmitted by the flow meter, and the pump follows this signal. Almost all SeaMetrics flow meters can be equipped

to transmit current loop signals proportional to the flow (4 milliamps at zero flow, rising to 20 milliamps at maximum flow). The following LMI pump models are equipped to respond to this signal:

A9, B9, C9, H9 Series  
L4, L8

### Programmable Metering Pumps - A9, B9, C9

The capabilities of these LMI pumps are expanded by the addition of microprocessor control. The main advantage for use with flow meters is increased flexibility. A built-in divider makes it possible to connect an IP or TX flow meter directly to the pump, powered by the pump's 12VDC power supply. Alternatively, a flow meter with 4-20 mA output can be connected using the 4-20 mA feature. If using an LMI pump with an IP, TX, or SPX flow meter, it is necessary to change the de-bounce setting (minimum input pulse width) from the factory setting of 15 down to 0 or 1, due to the short pulses these flow meters produce, particularly at high flow rates.

